

Technisches Datenblatt / technical Data sheet

Rangierpanel 19" 1HE
5x Metallbügel 110mm

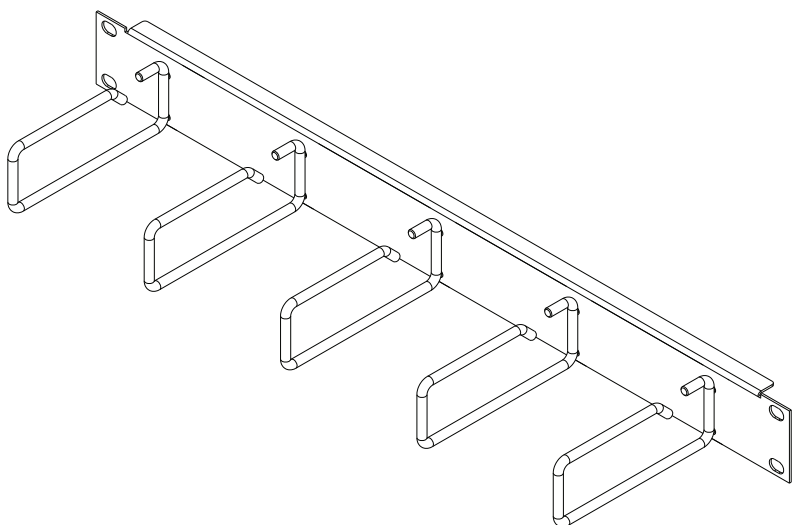
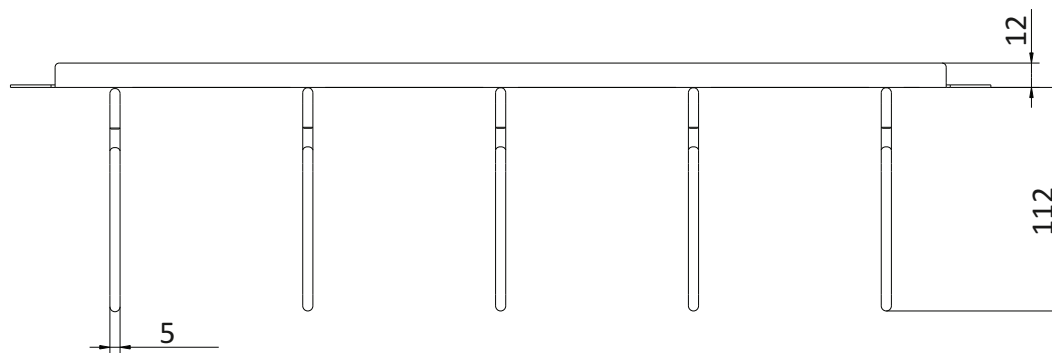
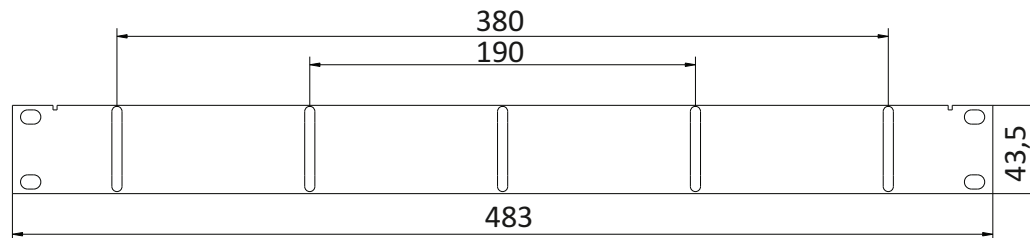

Bestell-Nummer
AVR5METC1E

Stahlblech verzinkt, pulverbeschichtet
RAL 7035

B A	Änderung Neuerstellung	15.05.18 22.09.15	LP AK	gez. / drawn	22.09.2015	Kandler
				gepr. / appr.	22.09.2015	Jungbeck
Änd./ rev. Index				Titel / titel: EasyLan Rangierpanel 19" 1HE 5x Metallbügel 110 mm		
Artikelnummer / article number: ZN-BL151074				Maße / Dimensions: mm		
				Original: DIN A4		
				Blatt / sheet 1 von / of 1		

