

Technisches Datenblatt / technical datasheet

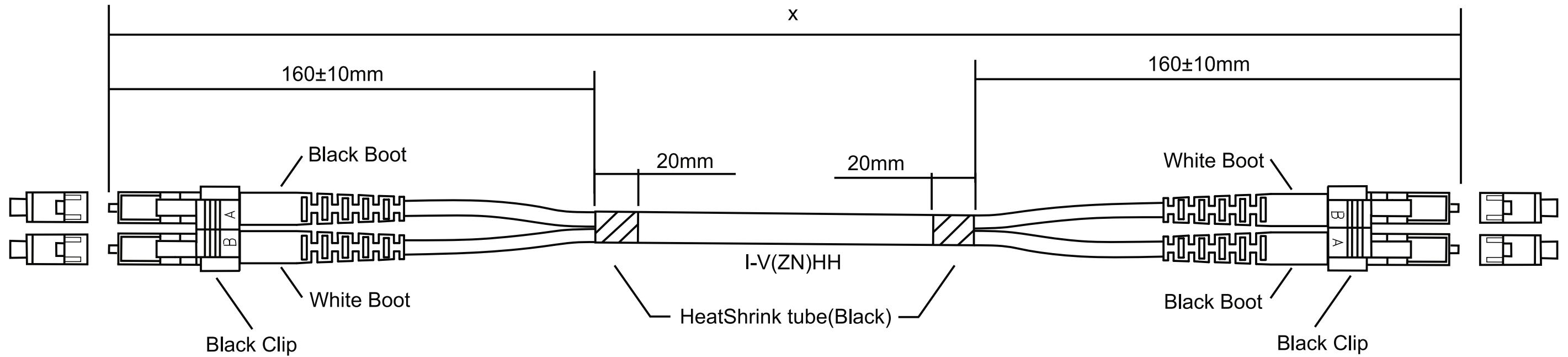

Längentoleranz

X < 5m	- 0,00 m + 0,07 m
X > 5m	- 1% + 1%

gez. / drawn	03.07.2017	LP
gepr. / appr.	03.07.2017	GF
Titel / titel: EasyLan I-V(ZN)HH Duplex LWL Patch- und Adapterkabel		
Artikelnummer / article number: ZN-FO171092_A		
a	Neuerstellung	03.07.2017 LP
Änd./ rev. Index	Änderung/ revision code	Datum/ date Name/ name



Maße / Dimensions: mm
Original: DIN A3
Blatt / sheet 1 von / of 1

Technisches Daten / technical data

OM3		OM3	
Faser	Multimode	Fiber	Fiber
Außenmantel	LSZH	Outer sheath	Outer sheath
Ferrulendurchmesser	8,2µm	Sleeve diameter	Sleeve diameter
Temperaturbereich in Betrieb	-20°C bis +70°C / -20°C to +70°C	Temperature during operating	Temperature during operating
Kabelaufbau	I-V(ZN)HH	Cable structure	Cable structure
Kabelmantelfarbe	aqua /aqua	Color Jacket	Color Jacket
OM4		OM4	
Faser	Multimode	Fiber	Fiber
Außenmantel	LSZH	Outer sheath	Outer sheath
Ferrulendurchmesser	8,2µm	Sleeve diameter	Sleeve diameter
Temperaturbereich in Betrieb	-20°C bis +70°C / -20°C to +70°C	Temperature during operating	Temperature during operating
Kabelaufbau	I-V(ZN)HH	Cable structure	Cable structure
Kabelmantelfarbe	violett / violet	Color Jacket	Color Jacket
OS2		OS2	
Faser	Singlemode	Fiber	Fiber
Außenmantel	LSZH	Outer sheath	Outer sheath
Ferrulendurchmesser	8,2µm	Sleeve diameter	Sleeve diameter
Temperaturbereich in Betrieb	-20°C bis +70°C / -20°C to +70°C	Temperature during operating	Temperature during operating
Kabelaufbau	I-V(ZN)HH	Cable structure	Cable structure
Kabelmantelfarbe	gelb / yellow	Color Jacket	Color Jacket

				gez. / drawn	03.07.2017	LP	 EasyLan [®] ...for a better connectivity
				gepr. / appr.	03.07.2017	GF	
Titel / titel:				EasyLan I-V(ZN)HH Duplex LWL Patch- und Adapterkabel			
Artikelnummer / article number:				ZN-FO171092_A			
Maße / Dimensions: mm				Original: DIN A3			
Blatt / sheet 1 von / of 1							