

MEGAMAN® TINA

MM75341/MM75342/MM75343 FDS74900v0
MM75345/MM75346 FDS75400v0

MEGAMAN®

Instruction Manual | Bedienungsanleitung | Manual de instrucciones | Manuale d'istruzioni | Manuel d'instructions |
Handleiding | Návod k použití



www.megaman.cz/resources/document-library/user-guides

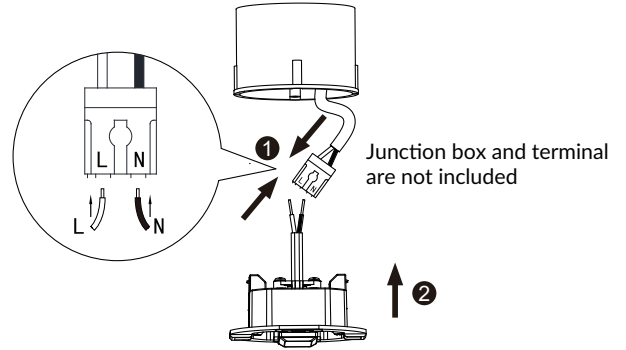
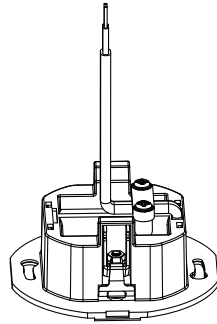
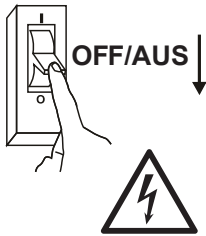

Installation method 1

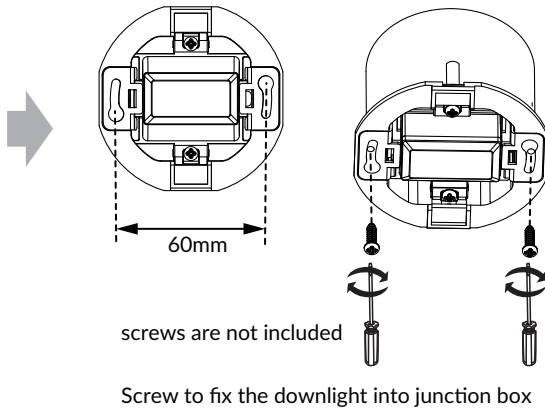

Installation method 2

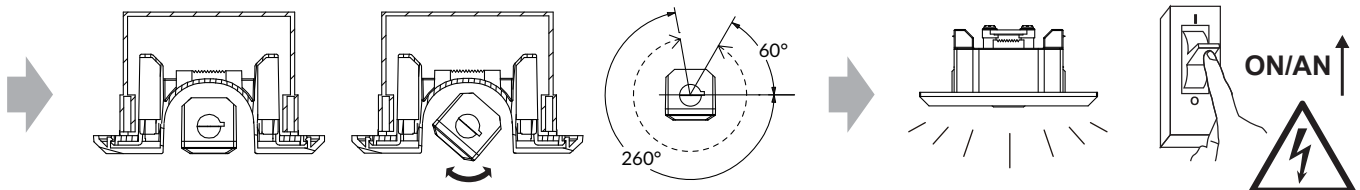
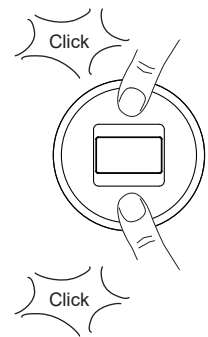
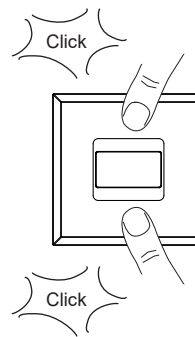
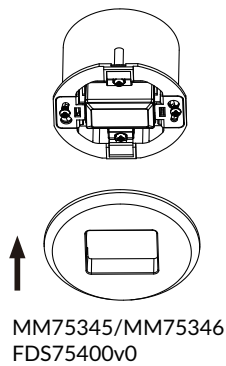
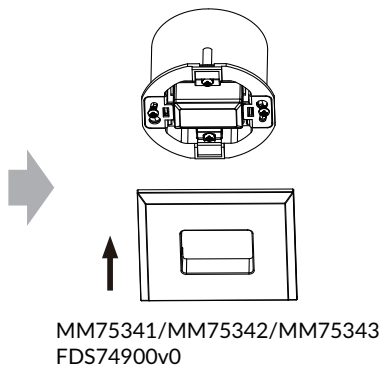
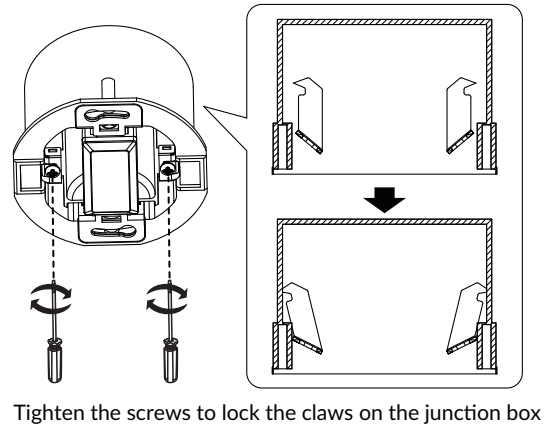

The light source contained in this luminaire shall only be replaced by the manufacturer or his service agent or a similar qualified person.
Das in dieser Leuchte enthaltene Leuchtmittel darf nur durch den Hersteller, seinen Kundendienst oder entsprechend qualifiziertes Fachpersonal ausgetauscht werden.
La fuente de iluminación de esta luminaria solo debe ser sustituida por el fabricante o su agente de servicio, o en su caso, por personal cualificado.
La sorgente luminosa contenuta in questo apparecchio deve essere sostituita esclusivamente dal produttore, dal suo rappresentante o da una persona similmente qualificata.
La source lumineuse contenue dans ce luminaire ne doit être remplacée que par le fabricant ou son agent de maintenance ou une personne de qualification équivalente.
De lichtbron in deze lamp mag alleen worden vervangen door de fabrikant, zijn serviceagent of een vergelijkbaar gekwalificeerd persoon.
Zdroj světla v tomto svítidle smí být vyměněn pouze elektrikářem, nebo servisním agentem výrobce.



The luminaires is not suitable for covering with thermally insulating material.
Die Leuchte ist nicht für Abdeckung mit Wärmeisolierung geeignet.
La luminaria no es apta para su revestimiento con material termoaislante.
Non coprire con materiale termoisolante.
Luminaires ne pouvant pas être recouverts d'un matériau isolant thermique.
De lamp is niet geschikt voor bedekking met thermisch isolatiemateriaal.
Svítidlo nesmí být překryto tepelným izolantem.

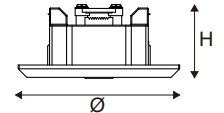

	P	I	CCT	λ	Ø(mm)	H(mm)
MM75341/MM75342/MM75343 FDS74900v0	1W	8mA	3000K	>0.5	85	36.5
MM75345/MM75346 FDS75400v0	1W	8mA	3000K	>0.5	85	36.5

Correct Disposal of This Product

 This marking indicates that this product should not be disposed with other household wastes throughout the EU. To prevent possible harm to the environment or human health from uncontrolled waste disposal, recycle it responsibly to promote the sustainable reuse of material resources. To return your used device, please use the return and collection systems or contact the retailer where the product was purchased. They can take this product for environmental safe recycling.

Die korrekte Entsorgung des Produkts

 Produkte, die mit diesem Symbol gekennzeichnet sind, gehören nicht in den Hausmüll, sondern müssen in Übereinstimmung mit der WEEE-Richtlinie entsorgt werden. Private Haushalte können verbrauchte Leuchten sowie Energiesparlampen und LED-Lampen kostenlos bei den Wertstoffhöfen bzw. Sammelstellen ihrer Kommune oder im Handel abgeben (in Deutschland, Österreich: freiwillige Rücknahmestellen). Gewerbliche Anwender können die Leuchten und Lampen kostenlos bei registrierten Sammelstellen anliefern.

IDV GmbH
Birkenweiherstr. 2
D-63505 Langenselbold
Germany
www.megaman.de

DC Input
Compatible
180-260V

220-
240V~

50/60
Hz

IP20



t_a
-30°C~+40°C

