

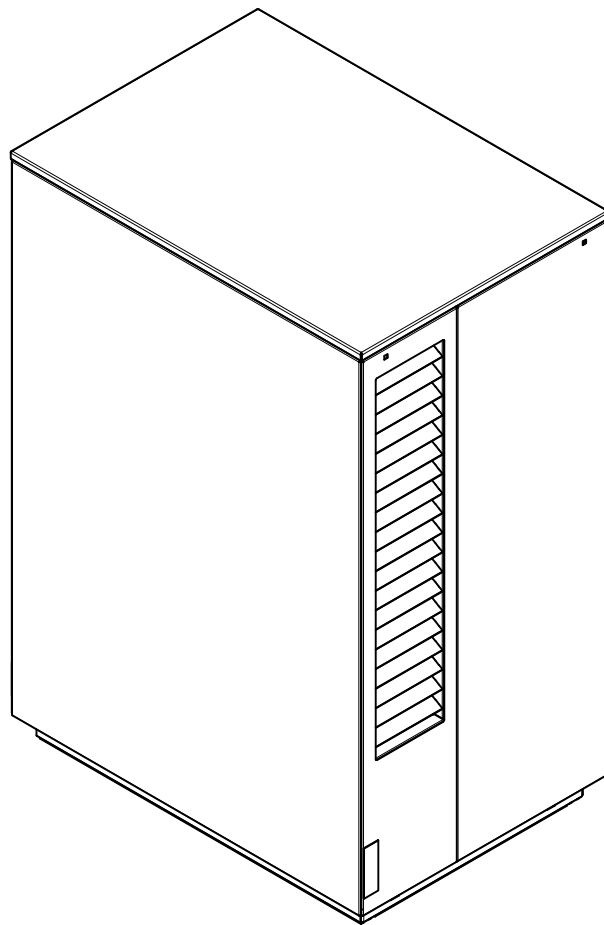

System M

Comfort 9/12 kW

091HOIAOC6
121HOIAOC6



Installation and Operating Instruction

Air-to-Water
Heat Pump
in Integral Design

Table of contents

1	Please read immediately	2
1.1	Intended use.....	2
1.2	Legal regulations and directives	2
1.3	Energy-efficient use of the heat pump.....	2
2	Intended use of the heat pump	3
2.1	Area of application.....	3
2.2	Operating principle.....	3
3	Scope of supply	4
3.1	Indoor unit	4
3.2	Outdoor unit.....	5
4	Transport	6
4.1	Outdoor unit.....	6
4.2	Indoor unit	6
5	Installation	8
5.1	Outdoor unit.....	8
5.2	Indoor unit	9
5.3	Acoustic emissions.....	9
6	Assembly / connection	10
6.1	Assembly of the refrigerant line and electric wire	10
6.2	Condensate drain.....	10
6.3	Connection on heating side	10
6.4	Temperature sensor connection	11
6.5	Electrical connection	12
6.6	Refrigerant pipe connections	15
7	Commissioning	17
7.1	General.....	17
7.2	Preparation.....	17
7.3	Procedure	17
8	Cleaning / maintenance	18
8.1	Maintenance	18
8.2	Cleaning the indoor unit	18
8.3	Cleaning the outdoor unit	18
9	Faults / troubleshooting	19
10	Decommissioning / disposal	19
11	Device information	20
12	Dimension drawing	22
12.1	Dimension drawing outdoor unit.....	22
12.2	Dimension drawing indoor unit.....	23
12.3	Dimension drawing legend.....	24
13	Diagrams	25
13.1	Characteristic curve heating 9 kW	25
13.2	Characteristic curve heating 12 kW	26
14	Product information as per Regulation (EU) No 813/2013, Annex II, Table 2	27
16	Information on the use of data	30
17	Declaration of conformity	31

1 Please read immediately

1.1 Intended use

This device is only intended for use as specified by the manufacturer. Any other use beyond that intended by the manufacturer is prohibited. This requires the user to abide by the relevant project planning documents. Please refrain from tampering with or altering the device.

1.2 Legal regulations and directives

This heat pump is designed for use in a domestic environment according to Article 1, Paragraph 2 k) of EC directive 2006/42/EC (machinery directive) and is thus subject to the requirements of EU directive 2014/35/EU (low-voltage directive). It is thus also intended for use by non-professionals for heating shops, offices and other similar working environments, agricultural establishments and hotels, guesthouses and other residential buildings.

The construction and design of the heat pump complies with all relevant EU directives, DIN and VDE regulations.

When connecting the heat pump to the power supply, the relevant VDE, EN and IEC standards are to be adhered to. Any further connection requirements stipulated by local utility companies must also be observed.

When connecting the heating system, all country-specific regulations must also be adhered to.

This unit can be used by children aged 8 and over and by persons with limited physical, sensory or mental aptitude or lack of experience and/or knowledge, providing they are supervised or have been instructed in the safe use of the unit and understand the associated potential dangers.

Children must not play with the device. Cleaning and user maintenance must not be carried out by children without supervision.

ATTENTION!

Work on the heat pump must only be performed by authorised and qualified after-sales service technicians!

NOTE

When operating or maintaining a heat pump, the legal requirements of the country where the heat pump is operated apply. Depending on the refrigerant fill quantity, the heat pump must be inspected for leaks at regular intervals by a certified technician, and these inspections must be recorded.

1.3 Energy-efficient use of the heat pump

By operating this heat pump you are helping to protect our environment. The heating system must be properly designed and dimensioned to ensure efficient operation. It is particularly important to keep water flow temperatures as low as possible in heating operation. All connected heat consumers should therefore be suitable for low flow temperatures. Raising the heating water temperature by 1 K corresponds to an increase in electric energy consumption of approx. 2.5 %. Low-temperature heating systems with flow temperatures between 30 °C and 50 °C are particularly well-suited for energy-efficient operation.

2 Intended use of the heat pump

2.1 Area of application

The air-to-water heat pump is to be used exclusively for heating of heating water. It can be used in new or existing heating systems.

The heat pump is suitable for mono energy and bivalent operation in outside air temperatures of up to -22 °C.

Proper defrosting of the evaporator is guaranteed by maintaining a heating water return temperature of more than 20 °C during continuous operation.

It is not designed for the increased heat consumption required when a building is being dried out. For this reason, the additional heat consumption should be met using special devices provided by the customer.

2.2 Operating principle

Surrounding air is drawn in by the fan and fed through the evaporator (heat exchanger). The evaporator cools the air, i.e. extracts heat from it. This extracted heat is then transferred to the working medium (refrigerant) in the evaporator.

The heat is "pumped" to a higher temperature level by increasing its pressure with the aid of the electrically driven compressors. It is then transferred to the heating water via the liquefier (heat exchanger).

Electrical energy is used to raise the temperature level of the heat from the environment. Because the energy extracted from the air is transferred to the heating water, this type of device is referred to as an air-to-water heat pump.

The air-to-water heat pump consists of the main components evaporator, fan and expansion valve, as well as the compressors, the liquefier and the electrical control system.

At low ambient temperatures, humidity accumulates on the evaporator in the form of frost, reducing the transfer of heat. Uneven accumulation during this process does not indicate a fault. The evaporator is defrosted automatically by the heat pump as required. Under certain atmospheric conditions, steam may be emitted from the air outlet.

3 Scope of supply

3.1 Indoor unit

Hydraulic systems (including a dual differential pressureless manifold)

- 1) 50 l buffer tank
- 2) *Actuator for 3-way reversing valve
- 3) 3-way reversing valve for generating domestic hot water
- 4) Regulated auxiliary circulating pump
- 5) Switch box with heating controller
- 6) Electric additional heater (2, 4 or 6 kW) for higher domestic hot water temperatures and for heating support
- 7) Safety valve, start-to-leak pressure 2.5 bar
- 8) Expansion vessel (24 l)
- 9) Universal hardware interface
- 10) *Regulated heat circulating pump primary circuit

Refrigeration circuit

- 11) Heat exchanger refrigerant / heating water
- 12) Compressor
- 13) 4-way reversing valve
- 14) Refrigeration circuit controller switch box
- 15) Filter dryer
- 16) Refrigerant line connections
- 17) Collector

* Option

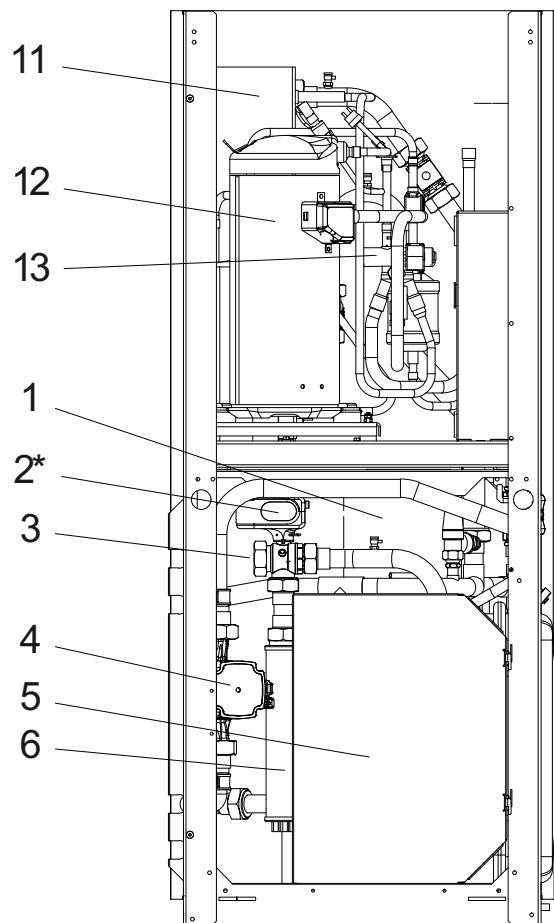
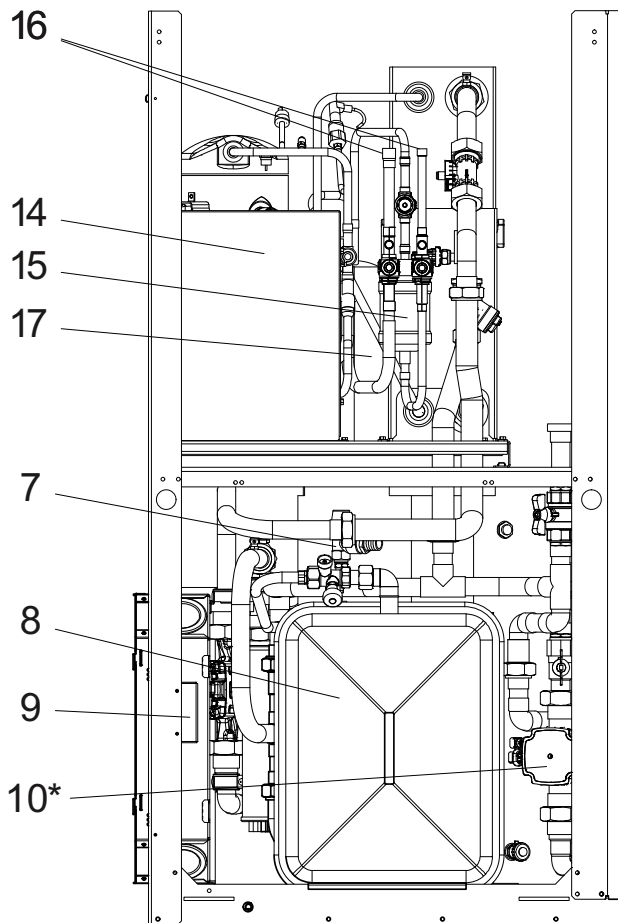

3.2 Outdoor unit

- 1) Evaporator
- 2) Fan
- 3) Expansion valve
- 4) Switch box
- 5) Connection for refrigerant line

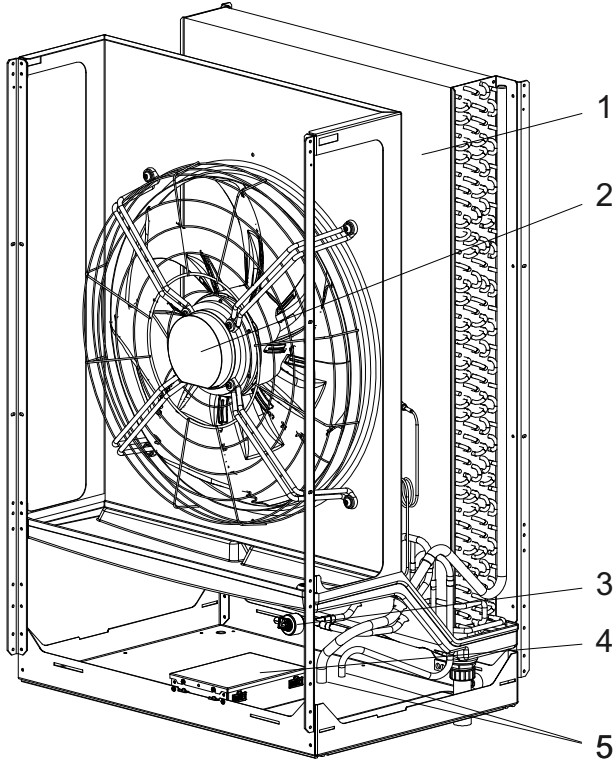

4 Transport

4.1 Outdoor unit

A pallet should be used to transport the heat pump to its final installation location. The outdoor unit can be transported with a lift truck, hand truck or similar.

Once the side sections have been removed, the outdoor unit can be lifted by the cover. For this, loosen the two screws at the top, tilt the metal plate to the side and remove at the top (see step 1-3)

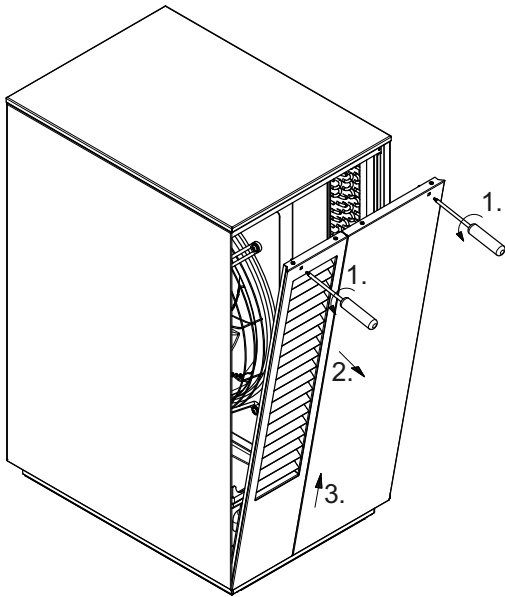

The casing panels must be dismantled in the order outlined below.

The right side panel must be removed first. For this, loosen the two screws at the top, tilt the metal plate to the right and remove at the top (see step 1-3). The left side panel can be removed in the same way.

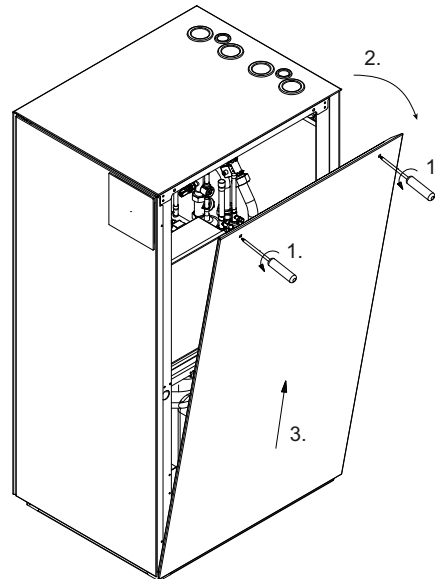

The front panel can then be removed.

For this, loosen the two screws on the right frame at the side. Push the metal plate approx. 10 mm to the right, then push it forwards slightly and remove at the top (see step 4-7). Disconnect the connection cables on the display screen.

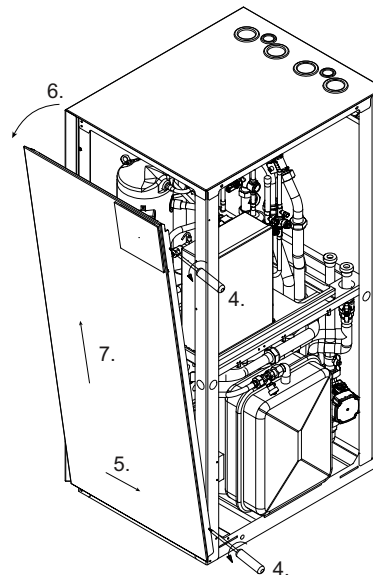

4.2 Indoor unit

A lift truck is suited for transporting the unit on a level surface. Carrying straps may be used if the heat pump needs to be transported on an uneven surface or carried up or down stairs. These straps can be passed directly underneath the pallet.

To lift from the pallet, the indoor unit can be tilted back by up to 45° and lifted by the handles on the back at the top.

Tilting more than 45° is not permitted.

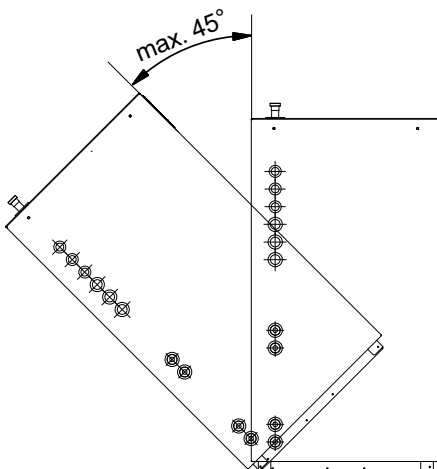

Once the two side sections have been removed, the device also has the option of inserting 3/4" support tubes through the holes in the frame.

After the final positioning at the installation location, remove the transport fastening on the sprung floor of the compressor on both sides.

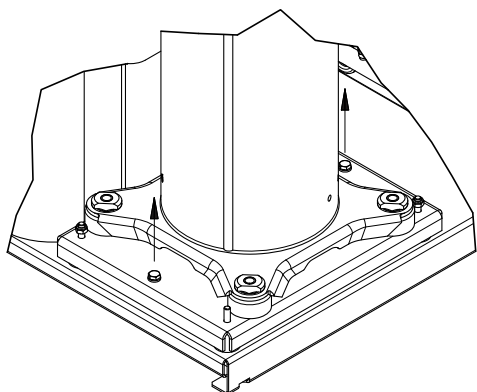

⚠ ATTENTION!

Before commissioning, the transport fastening must be removed.

5 Installation

5.1 Outdoor unit

Among other things, when selecting the installation locations for the indoor and outdoor units, ensure that the required length of refrigerant line is as short as possible. The standard length of a refrigerant line is 3 m. It is possible to have a specialist extend the refrigerant line to a length of 7 m up to a maximum of 10 m, provided that the information in see cap. 6.7 on page 17 has been heeded.

i NOTE

In snowy areas, the foundation must be of a sufficient height to guarantee a free air intake.

i NOTE

The cold air is blown out downwards at the side and can result in black ice on paths and platforms.

The outdoor unit must be installed on a permanently even, smooth and horizontal surface. The entire base of the frame should lie directly on the floor. To prevent small animals from entering the inside of the device, the connection hole in the base plate must be sealed where necessary.

The outdoor unit is designed for installation close to walls on even ground and for installation on a wall bracket. The outdoor unit must always be fixed in place at the installation location (Cap. 12.1 on page 22). The responsibility for the heat pump installation lies with the specialist system construction company. During the installation, local requirements such as building regulations, static load of the building, and wind exposure must be accounted for.

It must be possible to carry out maintenance work without hindrance. This is ensured if the clearance displayed below is maintained.

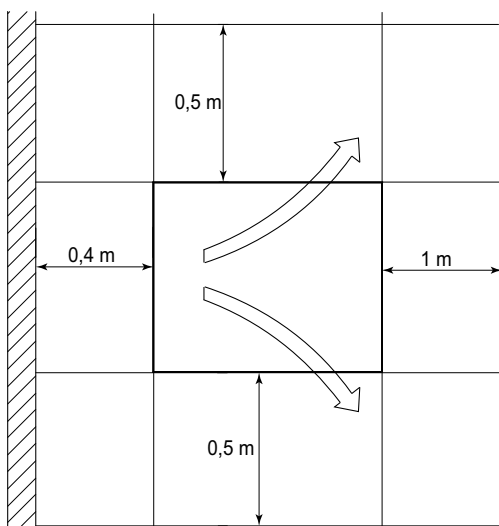

The specified dimensions are valid for stand-alone installation only.

If multiple outdoor units are set up next to each other, the required minimum distance at the side adds up. Ensure that the cold expelled air is not sucked in again.

i NOTE

Do not restrict or block the area around the intake or the air outlet area.

i NOTE

Observe country-specific building regulations!

i NOTE

The physical impacts must be observed for installation close to walls. No windows or doors should be present in the area surrounding the air outlet of the fan.

i NOTE

In cases of installation close to a wall, there may be more sediment in the intake and air outlet area due to the air flow. The colder outside air outlet should discharge in such a way as to not increase the heat losses in heated neighbouring rooms.

i NOTE

Installation in a hollow or in an inner courtyard is not permitted because cooled air collects at ground level and is drawn in again by the heat pump during extended periods of operation.

5.2 Indoor unit

The indoor unit must be installed in a frost-free, dry room on an even, smooth and horizontal surface. The entire base of the frame should lie directly on the floor to ensure an adequate soundproof seal. The surface must have sufficient load bearing capacity for the weight of the heat pump and the domestic hot water quantity.

The indoor unit must be installed so that maintenance work can be carried out without hindrance. This can be ensured by maintaining a clearance of approx. 1 m in front of and to the right of the heat pump.

The clearance specified on the left-hand side is required in order for the installation technician to connect the hydraulic and electrical systems.

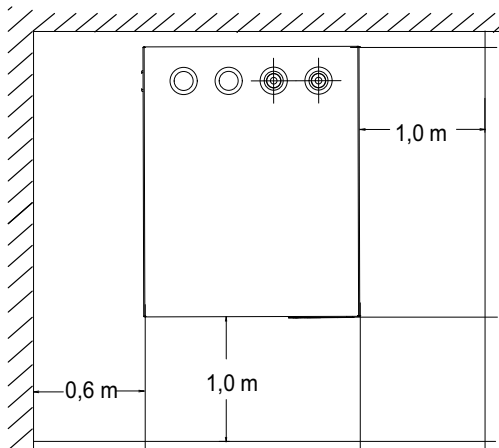

Neither frost nor temperatures higher than 35 °C must occur in the installation location at any time of the year.

The minimum volume of the room where the heat pump is installed must be no less than the following value depending on the refrigerant quantity in the device:

Performance level	Amount of refrigerant	Permissible concentration in the installation room according to DIN EN 378 (Tab. C.3)	Minimum permissible room volume for indoor installation
9 kW	4.20 kg R410A	0.39 kg/m ³	10.8 m ³
12 kW	4.78 kg R410A	0.39 kg/m ³	12.3 m ³

If the refrigerant quantity is increased, the room volume must be calculated according to the following formula:

[minimum permissible room volume m³] =
 [refrigerant quantity in kg] / [permissible concentration 0.39 kg/m³]

5.3 Acoustic emissions

The heat pump operates silently due to efficient sound insulation. Internal insulation measures should be carried out to prevent vibrations from being transmitted to the foundation or to the heating system.

6 Assembly / connection

6.1 Assembly of the refrigerant line and electric wire

The refrigerant lines and electric wires for connecting the indoor unit with the outdoor unit must be ordered separately as accessories.

To route the connection cables, create wall openings at a suitable point. The wall opening must be protected from water penetration according to the local conditions.

The wall openings should be sealed again correctly once the routing work is complete. (For connecting the electric wire, see cap. 6.5 on page 12, for connecting the refrigerant line, see cap. 6.6 on page 15).

6.2 Condensate drain

Condensate that forms during operation must be drained off frost free. To ensure proper drainage, the outdoor unit must be mounted horizontally.

The condensate tray offers various options for the condensate drain:

- Foundation covered with gravel. The leaching should be min. 1.5 l per kW of heat output per day, and the diameter of the drain pipe should be at least 50 mm.
- Channel into a waste water, rain water or drainage channel

If the condensate drain is installed at risk from frost, it must be protected from freezing with a condensate drain heater, which is available as a special accessory.

This must be connected in the outdoor unit, parallel to the nozzle ring heater (E4).

⚠ ATTENTION!

The frost line can vary according to the climatic region. The regulations of the countries in question must be observed.

6.3 Connection on heating side

Before connecting the heating system to the heat pump, the heating system must be flushed to remove any impurities, residue from sealants, etc. Any accumulation of deposits in the liquefier may cause the heat pump to completely break down.

A purging option must be arranged directly upstream and downstream of the indoor unit.

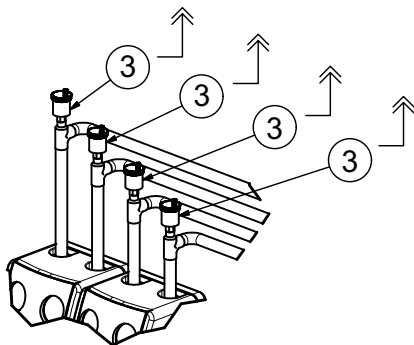

Once the heat pump has been connected to the heating system, it must be filled, purged and pressure-tested.

When doing so, it must be ensured that all heating circuits and isolating valves are open and that the 3-way reversing valve is in heating operation (pos. 1 factory default). Fill the heating system at the fill and drain cock (pos. 2) until system pressure (approx. 1.5 bar) is reached. A suitable fill hose with a pressure gauge should be used. When doing so, check all connections and the entire heating system for leakages. The heating system should be purged at the highest point (pos. 3, e.g. radiator, heat pumps connection).

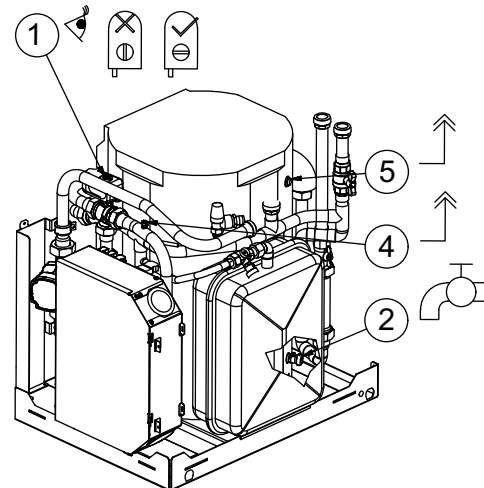

After all of the air has been purged here, the indoor unit must be purged at the valves of the electric auxiliary heating (pos. 4), buffer tank (pos. 5), dirt filter (pos. 6) and plate heat exchanger (pos. 7) until the heating water also exits free of bubbles here.

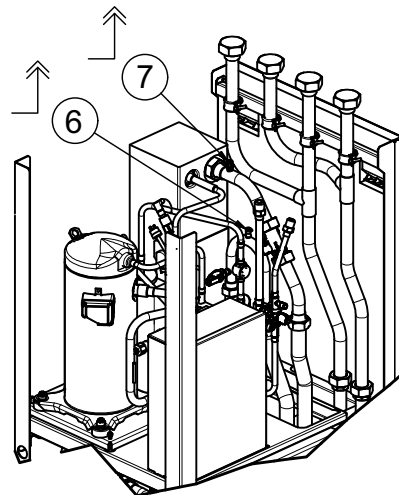

Finally, close the fill and drain cock, check the system pressure and top up if necessary.

The following points must be observed when filling the system:

- Untreated filling water and make-up water must be of drinking water quality (colourless, clear, free of sediments)
- Filling water and make-up water must be filtered (max. pore size 5 µm).

Scale formation in domestic hot water heating systems cannot be avoided, but in systems with flow temperatures below 60 °C, the problem can be disregarded. With high-temperature heat pumps and in particular with bivalent systems in the higher performance range (heat pump + boiler combination), flow temperatures of 60 °C and more can be achieved. The following standard values should therefore be adhered to with regard to the filling and make-up water according to VDI 2035, sheet 1: The total hardness values can be found in the table.

Total heat output in kW	Total Alkaline earths in mol/m ³ and/or mmol	Specific system volume (VDI 2035) in l/kW		
		< 20	≥ 20 < 50	≥ 50
		Total hardness in °dH		
< 50	≤ 2.0	≤ 16.8	≤ 11.2	< 0.11 ¹
50 - 200	≤ 2.0	≤ 11.2	≤ 8.4	
200 - 600	≤ 1.5	≤ 8.4	< 0.11 ¹	
> 600	< 0.02	< 0.11 ¹		

1. This value lies outside the permissible value for heat exchangers in heat pumps.

Abb. 6.1: Guideline values for filling and make-up water in accordance with VDI 2035

For systems with an above-average specific system volume of 50 l/kW, VDI 2035 recommends the use of fully demineralised water and a pH stabiliser to minimise the risk of corrosion in the heat pump and heating system.

⚠ ATTENTION!

With fully demineralised water, it is important to ensure that the minimum pH value of 7.5 (minimum permissible value for copper) is complied with. Failure to comply with this value can result in the heat pump being destroyed.

Minimum heating water flow rate

The minimum heating water flow rate through the heat pump must be assured in all operating states of the heating system. If the minimum heating water flow rate is not reached, the heat pump is blocked.

The nominal flow rate is specified depending on the max. flow temperature in the device information and must be taken into account during planning. For return temperatures under 30 °C, the flow must be designed for the nominal conditions.

The specified nominal flow rate (see "Device information") must be assured in all operating statuses. The installed flow rate monitoring is used only for switching off the heat pump in the event of an unusual and abrupt drop in the heating water flow rate and not to monitor and safeguard the nominal flow rate.

Frost protection

A method of manual drainage should be provided for heat pumps which are exposed to frost. The frost protection function of the heat pump manager is active whenever the heat pump manager and the heat circulating pump are ready for operation. The system must be drained if the heat pump is taken out of service or in the event of a power failure. The heating circuit should be operated with a suitable frost protection if heat pump systems are implemented in buildings where a power failure can not be detected (holiday home).

6.4 Temperature sensor connection

The following temperature sensors are already installed or must be installed additionally:

- Outside temperature (R1) is (NTC-2)
- Return temperature (R2) installed (NTC-10)
- Demand sensor (R2.2) installed (NTC-10)
- Flow rate monitoring with flow sensor (R3.1) installed (PT1000)
- Domestic hot water temperature (R3) installed (NTC-10)

6.4.1 Sensor characteristic curves

Temperature in °C	-20	-15	-10	-5	0	5	10			
NTC-2 in kΩ	14.6	11.4	8.9	7.1	5.6	4.5	3.7			
NTC-10 in kΩ	67.7	53.4	42.3	33.9	27.3	22.1	18.0			
PT 1000 in kΩ	0.92	0.94	0.96	0.98	1.0	1.02	1.04			
	15	20	25	30	35	40	45	50	55	60
	2.9	2.4	2.0	1.7	1.4	1.1	1.0	0.8	0.7	0.6
	14.9	12.1	10.0	8.4	7.0	5.9	5.0	4.2	3.6	3.1
	1.06	1.08	1.1	1.12	1.14	1.16	1.18	1.2	1.22	1.24

The temperature sensors to be connected to the heat pump manager must correspond to the values specified in the table.

6.4.2 Mounting the outside temperature sensor

The temperature sensor must be mounted in such a way that all weather conditions are taken into consideration and the measured value is not falsified.

- Mount on the external wall on the north or north-west side where possible
- Do not install in a "sheltered position" (e.g. in a wall niche or under a balcony)
- Not in the vicinity of windows, doors, exhaust air vents, external lighting or heat pumps
- Not to be exposed to direct sunlight at any time of year

Dimensioning parameter sensor lead	
Conductor material	Cu
Cable-length	50 m
Ambient temperature	35 °C
Laying system	B2 (DIN VDE 0298-4 / IEC 60364-5-52)
External diameter	4-8 mm

6.5 Electrical connection



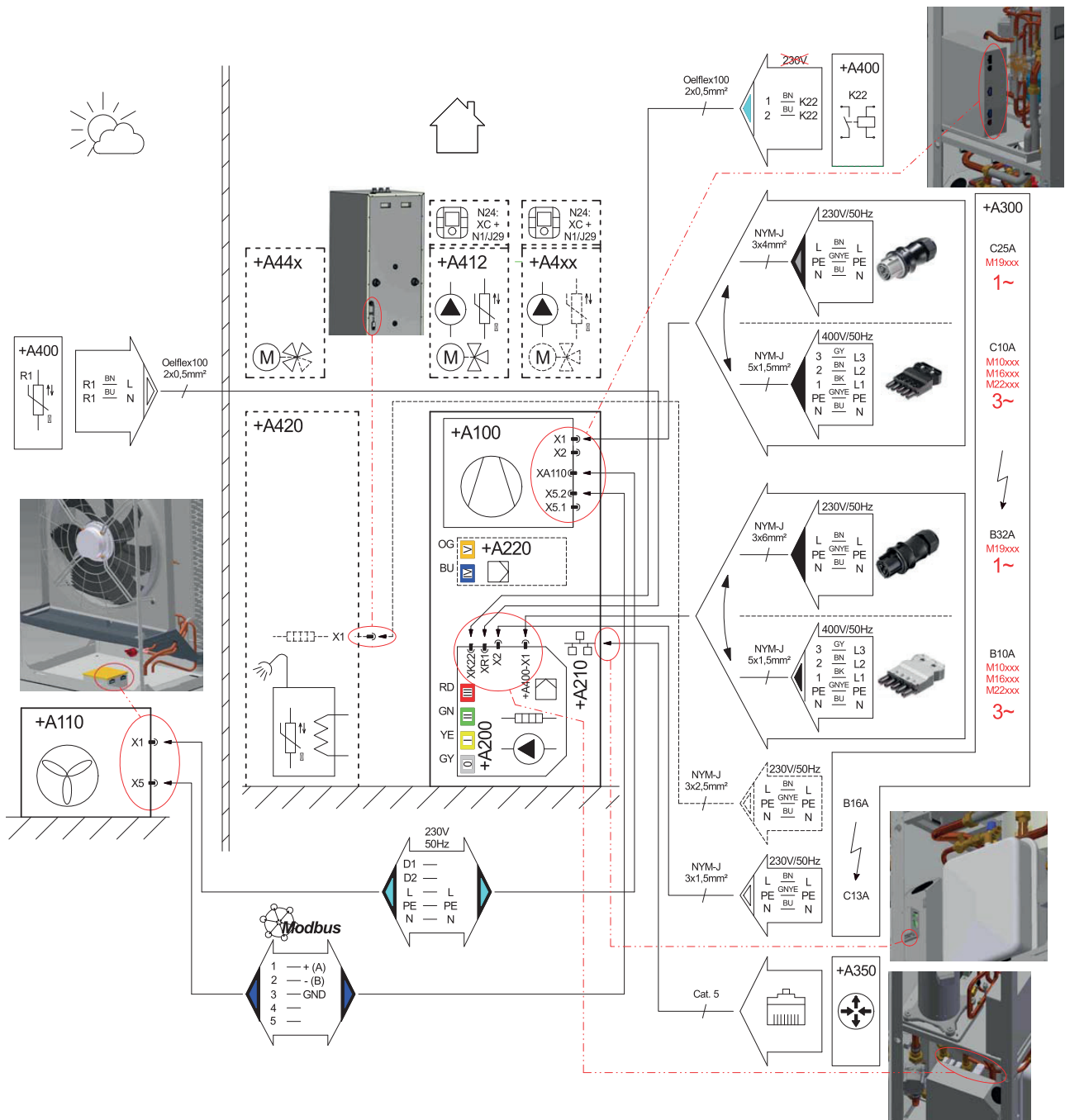















6.5.1 Circuit diagram



Symbol legend, see cap. 6.5.2 on page 13

Equipment marking, see cap. 6.5.3 on page 13

6.5.2 Symbol legend

	Connector
	Plug connection
	Compressor / refrigeration circuit
	Fan / outdoor unit
	Electrical distribution system
	Temperature sensor
	Floating contact
	Controller / WPM
	Heating / 2nd heat generator
	Pump / hydraulic module
	Indoors
	Outdoors
	Router
	LAN
	Mixer
	Domestic hot water
	Heat exchanger
	Smart-RTC (Intelligent room temperature controller)

6.5.3 Equipment markings

+A100	Refrigeration circuit
+A110	Outdoor unit
+A200	Hydraulics /WPM
+A210	Master unit
+A220	Expansion module WPM
+A300	Electrical distribution system
+A350	Router
+A400	Hydraulic installation (general)
+A411	Circuit 1: mixed
+A412	Circuit 2: mixed
+A420	Domestic hot water
+A441	Bivalent
+A442	Renewable
+A451	Cooling active
B3	domestic hot water thermostat
B4	Swimming pool water thermostat
E10.1	Electrical heater
E10.2/3	Oil/gas boiler
H5	Remote fault indicator
K21	Flange heater
K22	Utility block
K23	Disable contactor
K28	Switching heating/cooling
K31	Circulation system requirements
M13	Heat pump heating circuit 1
M15	Heat pump heating circuit 2
M16	Auxiliary circulating pump
M18	Domestic hot water circulating pump
M21	Mixer for heating circuit 1
M22	Mixer for heating circuit 2
M24	Domestic hot water circulation pump
M26	Mixer bivalent
M27	Mixer renewable
M28	Pump renewable
N5	Dew point monitor
N9	Room thermostat
N24	Smart-RTC
N27	Smart grid
R1	External sensor
R2.2	Demand sensor
R3	Domestic hot water sensor
R13	Sensor renewable
R34	Sensor bivalent
R35	Sensor circuit 1
R5	Sensor circuit 2
X1	Plug load feed
X2	Plug control voltage
X5.x	Communication
Xx	Connector

6.5.4 Electrical connection general

All connection cables must be provided on-site. The cable type (cross-section, conductor type, etc.) must be chosen taking into account the relevant electrical parameters (e.g. power, current, voltage, etc.) and the applicable VDE, EN and VNB regulations. Information on this can be found in the device information and the electrical documentation as a planning aid.

⚠ ATTENTION!

The plugs are protected against being pulled. They must be released with a small screwdriver before disconnecting.

6.5.5 Electrical connection indoor unit

For operating the heat pump, at least the following cables / signals must be connected:

■ Supply voltage / refrigeration circuit

An all-pole disconnecting device with a contact gap of at least 3 mm (e.g. utility blocking contactor or power contactor) must be installed in the refrigeration circuit power supply. A 3-pole circuit breaker with joint tripping of all outer conductors (trip current in accordance with device information) provides the short circuit protection taking into account the layout of the internal wiring. The relevant components in the heat pump contain an internal overload protection.

For connecting on the switch box of the refrigeration circuit modules on +A100-X1, check for the clockwise rotating field of the load feed.

Phase sequence: L1, L2, L3.

⚠ ATTENTION!

Ensure that there is a clockwise rotating field: With incorrect wiring the starting of the heat pump is prevented. A relevant warning is shown.

■ Communication / control voltage (hydraulics <-> refrigeration circuit)

The communication and control voltage cable from the hydraulic switch box (with heat pump manager) to the refrigeration circuit module are already pre-wired and end on the plugs +A100-X2 (control voltage) and +A100-X5.1 (communication). These may only have to be inserted.

■ Control voltage

The three-core supply cable for the heat pump manager (+A200-N1) is fed into the heat pump to the hydraulic switch box +A200-X2. The supply cable (L/N/PE ~230 V, 50 Hz) must have a continuous voltage. For this reason, it should be tapped upstream from the utility blocking contactor or be connected to the household current, because otherwise important protection functions could be lost during a utility block.

■ Utility block

The utility blocking contactor (K22) with 3 main contacts (1/3/5 // 2/4/6) and an auxiliary contact (NO contact 13/14) should be dimensioned according to the heat pump output and must be supplied on-site. The potential-free NO contact of the utility blocking contactor (13/14) is wired to the hydraulic switch box and must be connected on the relevant plug +A200-XK22 there. **Caution! Extra-low voltage!**

■ External sensor

The external sensor is connected to the hydraulic module via the +A200-XR1 plug

■ Supply voltage hydraulics

For the power supply to the 2nd heat generator, a wire must be routed to the device according to the power and connected to the hydraulic switch box on plug +A400-X1. In delivery state, the 2nd heat generator is configured to 6kW to guarantee that the increased heat consumption is met while drying out the building. In regular operation, this must be adapted to the actual required additional heating output (integrated system label).

To reduce it to 4 or 2 kW, one or two connections between +A400-K20 (relay 2nd heat generator) and +A400-F17 (safety temperature limiter)- both located in the hydraulic switch box - must be removed.

6.5.6 Electrical connection outdoor unit

A power supply (plug +A110-X1 <-> +A100-X5.2) and communication line (plug +A110-X5 <-> +A100-X5.2) must be routed parallel to the split line between the refrigeration circuit and the outdoor unit.

i NOTE

The assignment of the heat pump manager is outlined in the Quick Installation Guide. The functions are also printed on the label field of the heat pump manager

6.5.7 LAN / network connection

The heat pump is only designed for connection to the internet via a router. This ensures that the user can access the system at any time for setting parameters or for reading out information. Maintenance work or software updates are much easier.

A conventional network cable (Cat. 5) is required for connection, which is connected between an external router (+A350) and the network interface (+A210) of the indoor unit.

6.6 Refrigerant pipe connections

⚠ ATTENTION!

Work on the system must only be performed by authorised and qualified after-sales service technicians.

Certain requirements with regard to pipe length and rise must be complied with when installing refrigerant pipes. Once all conditions are met, the connection of the connecting pipe from the outdoor unit to the indoor unit can begin.

6.6.1 Requirements for the pipe length and rise

Model	Pipe size (mm) (external diameter x wall thickness)		Length A (m)			*additional refrigerant (g/m)
	Gas	Liquid	Normal	Min.	Max.	
9 kW	18 x 1	12 x 1	7	3	10	140
12 kW	18 x 1	12 x 1	7	3	10	140

The indoor unit of the heat pump is already filled with refrigerant. The standard pipe length is 3.0 m. Up to a length of 7 m, no additional refrigerant filling is required. For pipe lengths over 7 m, the system must be filled with additional refrigerant in accordance with the table.

⚠ ATTENTION!

Incorrect filling with refrigerant could lead to faults during operation.

⚠ ATTENTION!

The length of the refrigerant line is calculated based on the total line length from the respective connection point of the indoor unit to the outdoor unit.

Incorrect refrigerant filling or refrigerant lines over 10 m result in a risk of faults during operation and a complete failure of the heat pump.

*Example: When installing the 9 kW model at a distance of 10 m, 420 g refrigerant must be added according to the following calculation: $(10 - 7) \times 140 \text{ g} = 420 \text{ g}$

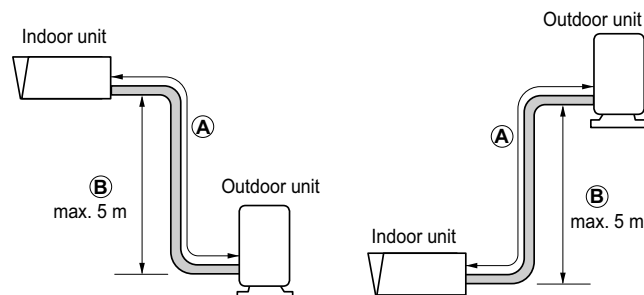

i NOTE

If the indoor unit is mounted 2.5 m or more metres higher or lower than the outdoor unit, a cooling technology specialist must perform a separate check to ensure that the devices for conveying the oil up and down the pipes have been installed correctly in the exhaust gas pipe. The maximum rise (B) between the indoor and outdoor units is 5 m.

i NOTE

The specified operating data of the device refers to the standard pipe length, see device information.

6.6.2 Pipe connection

The connection points for the refrigerant lines must be established using the brazing process. All generally applicable installation and work steps must be followed for this.

During the brazing process, the pipe system must be flushed with an inert gas (e.g. nitrogen). The adjacent components must be suitably cooled to prevent them being damaged.

6.6.3 Leak test and evacuation

Air and moisture in the cooling system have unwanted effects as outlined below.

- 1) The pressure in the system increases.
- 2) The operating current increases.
- 3) The cooling (or heating) output falls.
- 4) Moisture in the cooling circuit can freeze and block the capillary tubes.
- 5) Water can cause corrosion on parts in the cooling system.

This means that the connection pipes must be checked for leaks and pumped empty to remove any moisture and non-condensable gases from the system.

Step 1: Preparation

Ensure that every pipe (liquid and intake side) between the indoor and outdoor unit is connected correctly. Ensure that both maintenance valves on the liquid and intake of the indoor unit are closed at this point.

Step 2: Leakage tightness test

- Connect a dry nitrogen gas cylinder (with Schrader) on the maintenance valve.
- Apply 40 bar dry nitrogen to the system. Close the cylinder valve once the test pressure is reached. The next step is to search for leaks with liquid soap.

i NOTE

In order to prevent liquid nitrogen from entering the cooling system, the top side of the gas cylinder must be higher than the bottom side when pressure is building in the system.

- All pipe connections (internal and external) must be checked for leaks with liquid soap. Bubbles indicate a leak. The soap must then be wiped away with a clean cloth.
- If no leaks are found on the system, drain off the nitrogen.

Step 3: Evacuation

- Connect the vacuum pump on the maintenance valve (with Schrader).
- Run the vacuum pump until the relevant vacuum is reached. An absolute pressure of at least 0.2 mbar must be achieved during evacuation. Pressures below 0.2 mbar are advisable, however.
- Close the vacuum pump and start filling immediately.

Step 4: Filling

Once the leakage tightness test and evacuation have been carried out correctly, open the maintenance valves on the indoor unit. For refrigerant lines > 7.0 m, top up the refrigerant accordingly.

The heat pump is now ready for use.

7 Commissioning

7.1 General

To ensure that commissioning is performed correctly, it should only be carried out by an after-sales service technician authorised by the manufacturer.

i NOTE

Personal protective equipment (protective goggles, safety shoes and gloves where necessary) must be used when working on the device. Components with plastic parts must be protected from impact (e.g. from tools) to prevent damage to these components.

7.2 Preparation

The following items must be checked prior to commissioning:

- All of the indoor unit connections must be installed.
- All of the outdoor unit connections must be installed.
- The domestic hot water cylinder must be completely filled and the domestic hot water feed open.
- All valves which could impair the proper flow of the heating water in the heating circuit must be open.
- The air intake and air outlet paths must be clear.
- The settings of the master unit must be adapted to the heating system in accordance with the operating instructions.
- The heating water circuit and the buffer tank must be completely filled and purged.
- Ensure that the condensate drain functions properly.
- The outflow from the heating water pressure relief valve must also function correctly.
- The system must be completely filled with refrigerant and the shut-off devices completely open.

7.3 Procedure

The heat pump is commissioned using the master unit or a smart device paired with the pump. See the "Operation" manual for instructions on operation, adjustment and set-up.

At heating water temperatures under 7 °C, commissioning is not possible. The water in the buffer tank must be heated with the 2nd heat generator to at least 20 °C.

To ensure problem-free commissioning, the following procedure is to be implemented:

- 1) Close all consumer circuits.
- 2) Ensure that the heat pump has the correct water flow.
- 3) Wait until a return temperature of at least 25 °C has been reached.
- 4) Now slowly reopen the heating circuit valves in succession so that the heating water flow rate is constantly raised by slightly opening the respective heating circuit. The heating water temperature in the buffer tank must not be allowed to drop below 20 °C during this process. This ensures that the heat pump can be defrosted at any time.
- 5) When all heating circuits are fully open and a return temperature of at least 20 °C is maintained, the commissioning is complete.

⚠ ATTENTION!

Operating the heat pump at low system temperatures may cause the heat pump to break down completely.

8 Cleaning / maintenance

8.1 Maintenance

To protect the paintwork, avoid leaning anything against the device or putting objects on the device. The outdoor unit and indoor unit of the heat pump can be cleaned and polished with conventional agents, e.g. car polish.

i NOTE

Never use cleaning agents containing sand, soda, acid or chloride, as these can damage the surfaces.

To prevent faults due to sediment in the heat exchangers, care must be taken to ensure that no impurities can enter either the heat source system or the heating system. In the event that operating malfunctions due to contamination occur nevertheless, the system should be cleaned as described below.

8.2 Cleaning the indoor unit

⚠ ATTENTION!

The integrated dirt trap must be cleaned at regular intervals.

The maintenance intervals should be defined according to the degree of soiling in the system. The filter insert should also be cleaned.

For cleaning, the heating circuit must be made pressureless in the vicinity of the dirt trap, the filter compartment unscrewed, and the filter insert removed and cleaned. Assembly carried out in reverse order requires attention to correct assembly of the screen inserts and tightness of the screw joints.

The ingress of oxygen into the heating water circuit may result in the formation of oxidation products (rust), particularly if steel components are used. These enter the heating system via the valves, the circulating pumps and/or plastic pipes. A diffusion-resistant installation is therefore essential, especially with regard to the complete piping.

i NOTE

We recommend the installation of a suitable corrosion protection system to prevent the formation of deposits (e.g. rust) in the liquefier of the heat pump. We recommend equipping diffusion-open heating systems with an electrophysical corrosion protection system (e.g. ELYSATOR system).

Residue from lubricants and sealants may also contaminate the heating water.

In the event of severe contamination leading to a reduction in the performance of the liquefier in the heat pump, the system must be cleaned by a heating technician.

Based on current information, we recommend using a 5 % phosphoric acid solution for cleaning purposes. However, if cleaning needs to be performed more frequently, a 5 % formic acid solution should be used.

In both cases, the cleaning fluid should be at room temperature. We recommend flushing the heat exchanger in the direction opposite to the normal flow direction.

To prevent acidic cleaning agents from entering the heating system circuit, we recommend connecting the flushing device directly to the flow and return of the liquefier of the heat pump.

It is then important that the system be thoroughly flushed using appropriate neutralising agents to prevent any damage from being caused by cleaning agent residue remaining in the system.

Acids must be used with care and the regulations of the employers liability insurance associations must be adhered to.

The instructions of the cleaning agent manufacturer must always be observed.

8.3 Cleaning the outdoor unit

The evaporator, fan and condensate drain should be cleaned of contamination (leaves, twigs, etc.) before each new heating period.

⚠ ATTENTION!

Before opening the device, ensure that all circuits are disconnected from the power supply.

To prevent the evaporator and the condensate tray from being damaged, do not use hard or sharp objects when cleaning.

Under extreme weather conditions (e.g. snow drifts), ice may form on the air intake and air outlet areas in individual cases. If this happens, the ice must be removed from the vicinity of the intake and air outlet area to ensure that the minimum air flow is maintained.

To ensure proper drainage from the condensate tray, it must be regularly inspected and cleaned, if necessary.

9 Faults / troubleshooting

This heat pump is a quality product and is designed for trouble-free operation. In the event that a fault should occur, it will be indicated on the master unit display.

If you cannot correct the fault yourself, please contact your after-sales service technician.

⚠ ATTENTION!

Work on the system must only be performed by authorised and qualified after-sales service technicians.

⚠ ATTENTION!

Before opening the device, ensure that all circuits are disconnected from the power supply.

i NOTE

Personal protective equipment (protective goggles, safety shoes and gloves where necessary) must be used when working on the device. Components with plastic parts must be protected from impact (e.g. from tools) to prevent damage to these components.

10 Decommissioning / disposal

Before removing the heat pump, disconnect the machine from the power source and close all inflow and outflow valves. The heat pump must be dismantled by trained personnel. All environmentally-relevant requirements regarding the recovery, recycling and disposal of materials and components should be observed in accordance with the applicable standards. Particular attention should be paid to the proper disposal of refrigerants and refrigerant oils.

11 Device information

Type and order code		091HOIAOC6	121HOIAOC6
1 Design		System M Comfort	System M Comfort
Heat source		Air	Air
1.1 Energy efficiency class high temperature		A+	A+
1.2 Energy efficiency class low temperature		A++	A++
1.3 Seasonal coefficient of performance (COP) for average climate 35 °C/ 55 °C (SCOP in accordance with EN 14825)		4.2 / 3.0	4.0 / 3.1
1.4 Controller		Integrated	Integrated
1.5 Heat generator installation location		Indoors	Indoors
1.6 Heat source installation location		Outdoors	Outdoors
1.7 Thermal energy metering		Integrated	Integrated
1.8 Performance levels		1	1
2 Operating limits			
2.1 Heating water flow / return ¹	°C	up to 60 ±2 / from 20	up to 60 ±2 / from 20
2.2 Air (heating) ¹	°C	-22 to +35	-22 to +35
3 Flow² / sound			
3.1 Heating water flow / free compression			
Nominal flow in accordance with EN 14511A7/ W35...30	m ³ /h / Pa	1.4 / 31000	1.9 / 18000
A7 / W45...40	m ³ /h / Pa	1.3 / 40000	1.8 / 24000
A7 / W55...47	m ³ /h / Pa	0.8 / 60000	1.1 / 55000
3.2 Minimum heating water flow	m ³ /h	0.8 / 60000	1.1 / 55000
3.3 Sound power level according to EN 12102 with A7 / W55 outdoors Normal operation / reduced operation ³	dB(A)	54 / 53	55 / 54
3.4 Sound pressure level at a distance of 10 m, outdoors ⁴ Normal operation / reduced operation ³	dB(A)	25 / 24	25 / 24
3.5 Sound power level in accordance with EN 12102 at A7 / W55 indoors	dB(A)	45	45
3.6 Sound pressure level at a distance of 1 m indoors ⁴	dB(A)	34	34
3.7 Air flow Normal operation / reduced operation ³	m ³ /h	3300 / 2900	3800 / 3000
4 Dimensions, weight and filling quantity			
4.1 Device dimensions ⁵ indoors without connections	H x W x L mm	1400 x 600 x 750	1400 x 600 x 750
outdoors without connections	H x W x L mm	1230 x 850 x 600	1230 x 850 x 600
4.2 Device connections heating	inches	G 1 1/4" external thread	G 1 1/4" external thread
4.3 Weight indoor component without refrigeration circuit module / refrigeration circuit module / outdoor component	kg	100 / 64 / 90	100 / 71 / 98
4.4 Refrigerant / total filling weight	type / kg	R410A / 4.2 ⁶	R410A / 4.78 ⁶
4.5 GWP value / CO ₂ equivalent	-- / t	2088 / 8.7	2088 / 9.9
4.6 Lubricant / total filling quantity	type / litres	Polyolester (POE)/1.24	Polyolester (POE)/1.24
4.7 Volume of heating water in the indoor component	litres	65	65
4.8 Electrical pipe heater Adjustable levels (factory setting)	kW	2; 4; 6 (6)	2; 4; 6 (6)
4.9 Buffer tank			
Nominal volume /max. Operating pressure	litres / bar	50 / 3.0	50 / 3.0
4.10 Volume expansion vessel	litres	24	24
4.11 Start-to-leak pressure, safety valve	bar	2.5	2.5
5 Electrical connection			
5.1 Supply voltage / fusing	Compressor Pipe heater	3~/N/PE 400 V (50 Hz) / C10A 3~/N/PE 400 V (50 Hz) / B10A	3~/N/PE 400 V (50 Hz) / C10A 3~/N/PE 400 V (50 Hz) / B10A
5.2 Control voltage / fusing via WPM		1~/N/PE 230 V (50 Hz) / C13A	1~/N/PE 230 V (50 Hz) / C13A
5.3 Degree of protection according to EN 60 529 indoors / outdoors		IP 21 / IP 24	IP 21 / IP 24

Type and order code		091HOIAOC6	121HOIAOC6		
5.4 Starting current limiter		Yes	Yes		
5.5 Rotary field monitoring		Yes	Yes		
5.6 Starting current	A	21	19		
5.7 Nominal power consumption A2/W35 / max. consumption ²	kW	1.7 / 3.3	2.3 / 4.0		
5.8 Nominal current A2/W35 / cos φ	A / --	3.0 / 0.8	4.1 / 0.8		
5.9 Power consumption compressor protection (per compressor)	W / --	_6	70		
5.10 Power consumption of fan	W	up to 175	up to 200		
6 Complies with the European safety regulations		see CE declaration of conformity	see CE declaration of conformity		
7 Additional model features					
7.1 Type of defrosting		Reverse circulation	Reverse circulation		
7.2 Condensate tray frost protection / Water in device is protected from freezing ⁷		yes	yes		
7.3 Max. operating overpressure (heat sink)	bar	2.5	2.5		
8 Heat output / COP ^{2 6}					
8.1 Heat output / COP		EN 14511		EN 14511	
	Performance level	1	2	1	2
	with A-7 / W35	5.0 / 3.0	-	7.0 / 2.9	-
	with A2 / W35	6.2 / 3.9	-	8.6 / 3.8	-
	with A7 / W35	8.1 / 4.9	-	11.0 / 4.7	-
	with A7 / W45	7.6 / 3.5	-	10.3 / 3.4	-
	with A7 / W55	7.5 / 2.8	-	10.0 / 2.7	-

1. For air temperatures between -22 °C and -5 °C, flow temperature increasing from 45 °C to 60 °C

2. These data indicate the size and capacity of the system according to EN 14511.

For an analysis of the economic and energy efficiency of the system, other parameters, in particular the defrosting capacity, the bivalence point and regulation, should also be taken into consideration. These figures are only achieved with clean heat exchangers.

Information on maintenance, commissioning and operation can be found in the respective sections of the installation and operating instructions. The specified values, e.g. A2 / W35, have the following meaning: outside air temperature 2 °C and heating water flow temperature 35 °C.

3. The heat output and COP is reduced by approx. 5 % in lower operation.

4. The specified sound pressure level represents the free sound area level. The measured value can deviate by up to 16 dB(A), depending on the installation location.

5. Note that additional space is required for pipe connections, operation and maintenance.

6. Indoor and outdoor component must be connected with two refrigerant pipes (high and low pressure). The length information refers to one section. The specified technical data applies to a refrigerant pipe length of 3m per section (minimum permissible).

For longer refrigerant pipes, the heat output is reduced by 2 % and the coefficient of performance (COP) is reduced by 3 % per meter section length. The maximum permissible section length (without adjusting the refrigerant quantity) is 7 m. The refrigerant quantity pre-filled at the factory is sufficient up to this length.

From a single pipe length of 7 m, the refrigerant quantity must be adjusted. The maximum permissible length of the pipe with refrigerant top-up is 10 m.

The specified directives for routing refrigerant pipes and topping up refrigerant can be found in the installation and operating instructions.

7. The heat circulating pump and the heat pump controller must always be ready for operation.

12 Dimension drawing

12.1 Dimension drawing outdoor unit

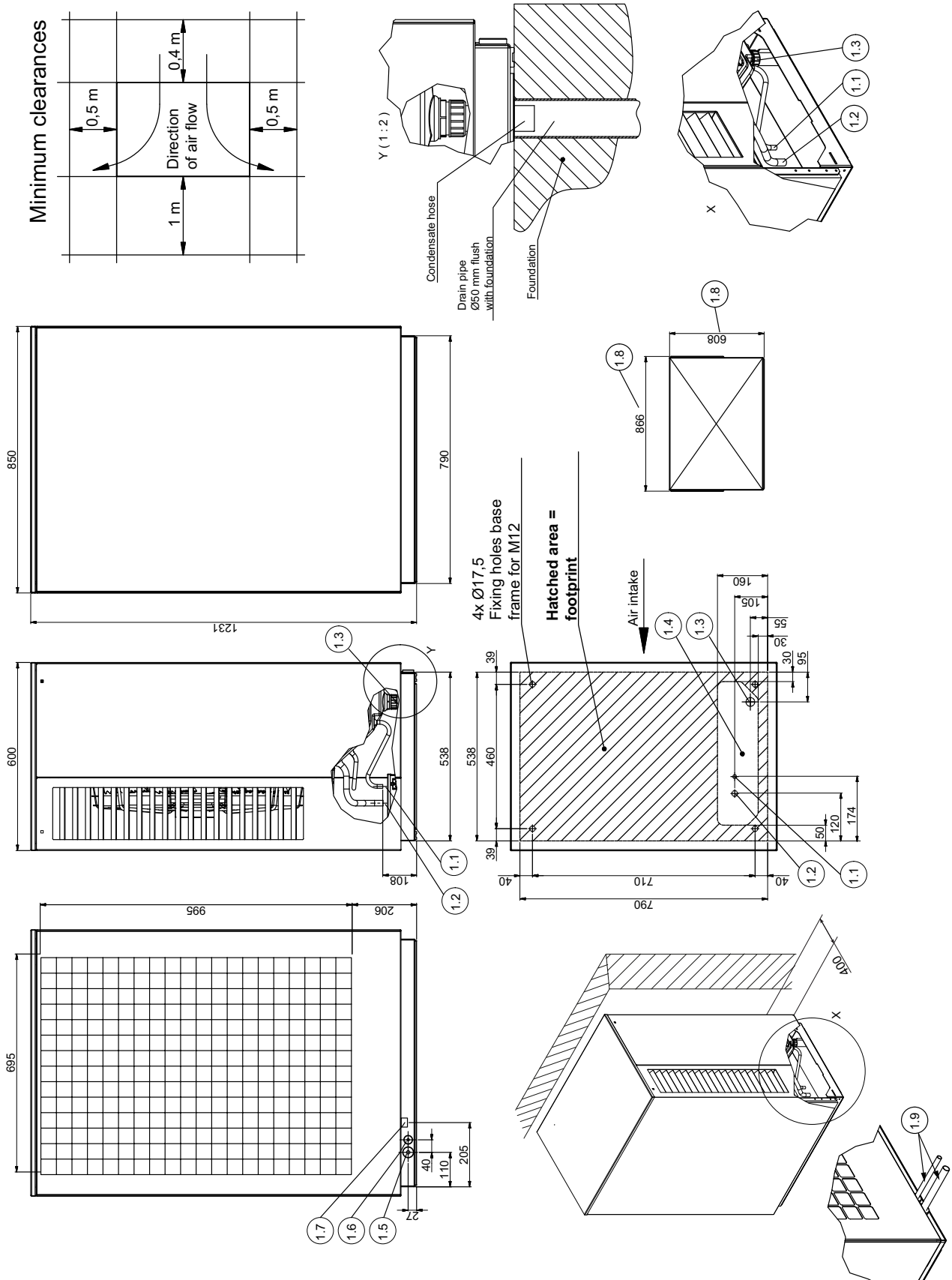

12.2 Dimension drawing indoor unit

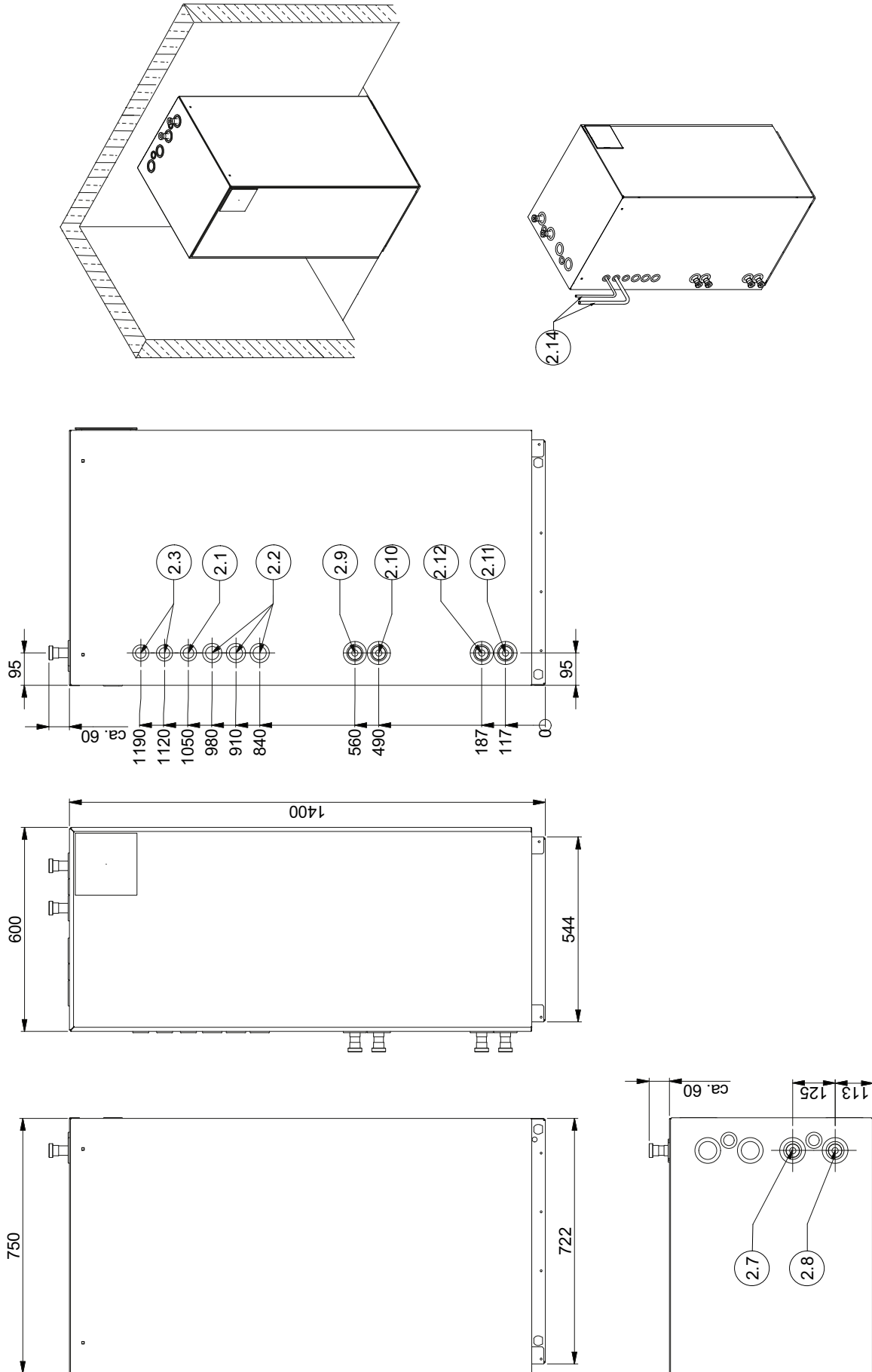

12.3 Dimension drawing legend

1 Outdoor unit

- 1.1 Connection refrigerant line 12 x1 mm outdoor unit
- 1.2 Connection refrigerant line 18 x 1 mm outdoor unit
- 1.3 Condensate drain
- 1.4 Feedthrough refrigerant lines and electric wires; condensate hose
- 1.5 Optional feedthrough refrigerant line 18 mm
- 1.6 Optional feedthrough electric wires 12 mm
- 1.7 Optional feedthrough, electric wire
- 1.8 External dimensions wood design variant
- 1.9 MPRO16 accessory set for optional rear connection of the refrigerant lines

2 Indoor unit

- 2.1 Outlet overpressure
- 2.2 Feed-through electric wire indoor unit
- 2.3 Feed-through refrigerant line indoor unit
- 2.7 Flow heating G 1 1/4"
- 2.8 Return heating G 1 1/4"
- 2.9 Flow domestic hot water cylinder G 1 1/4"
- 2.10 Return domestic hot water cylinder G 1 1/4"
- 2.11 Flow bivalent G 1 1/4"
- 2.12 Return bivalent G 1 1/4"
- 2.14 Included pipe set for side connection of the refrigerant lines

13 Diagrams

13.1 Characteristic curve heating 9 kW

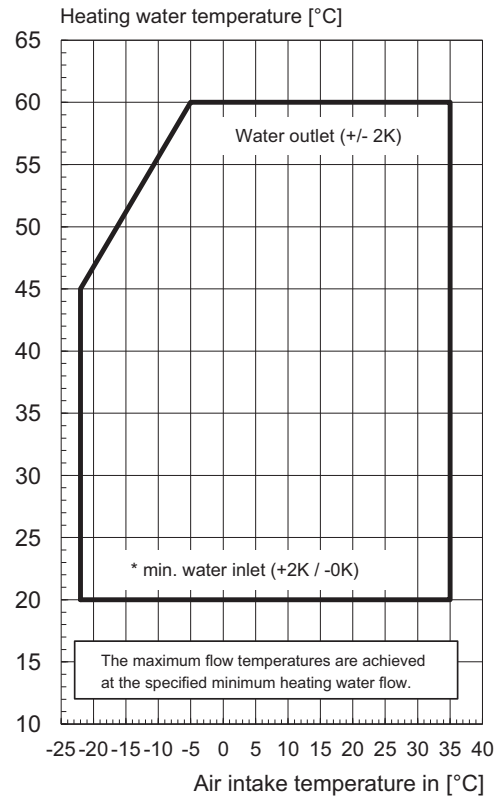
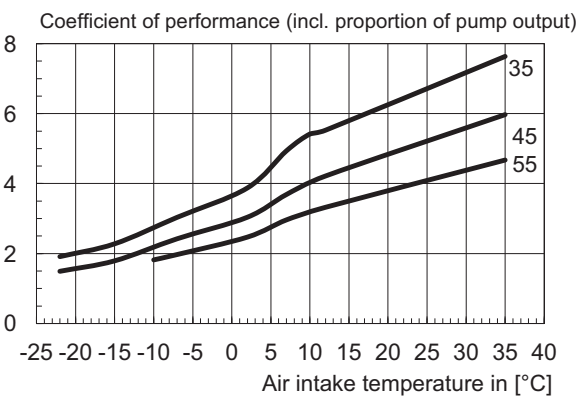
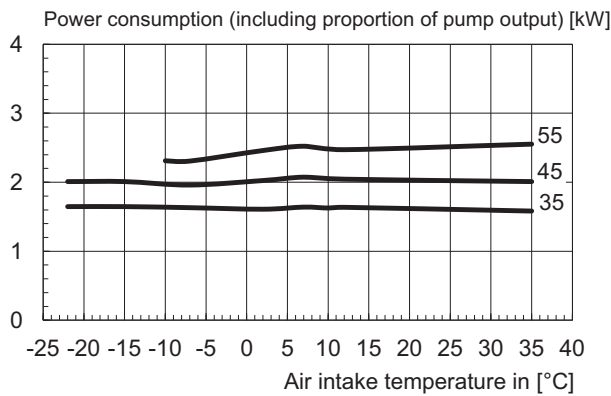
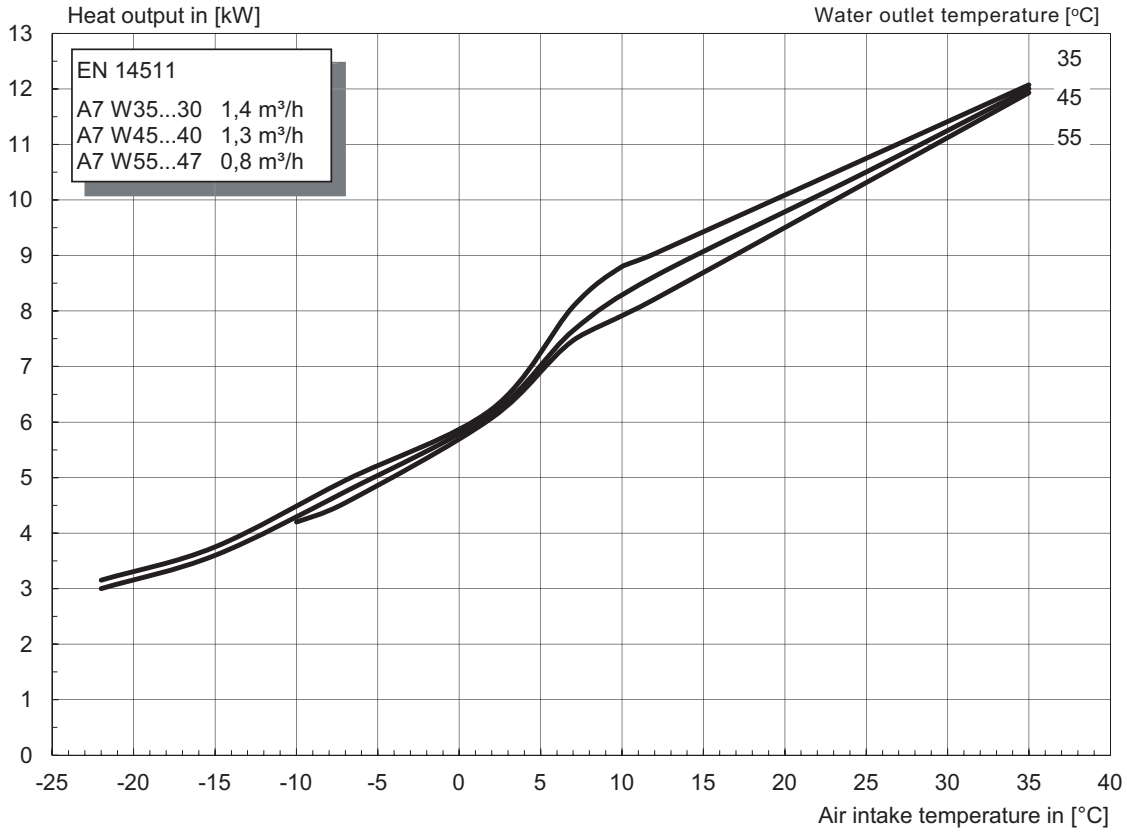

13.2 Characteristic curve heating 12 kW

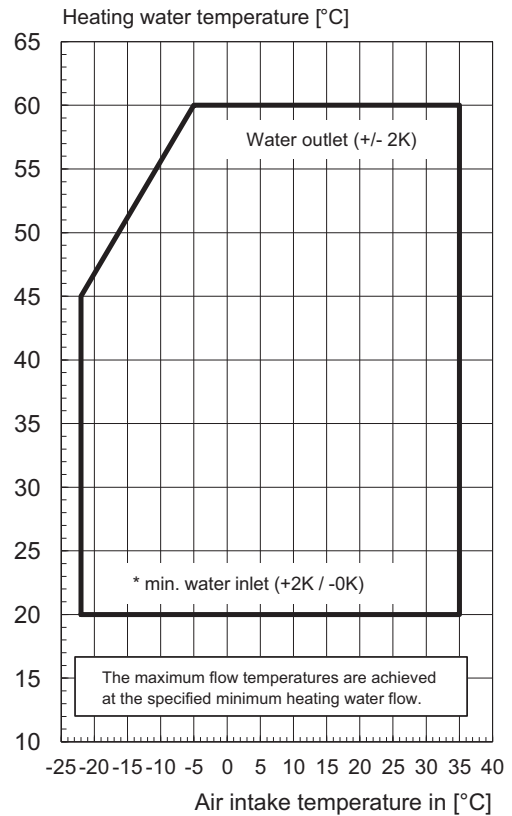
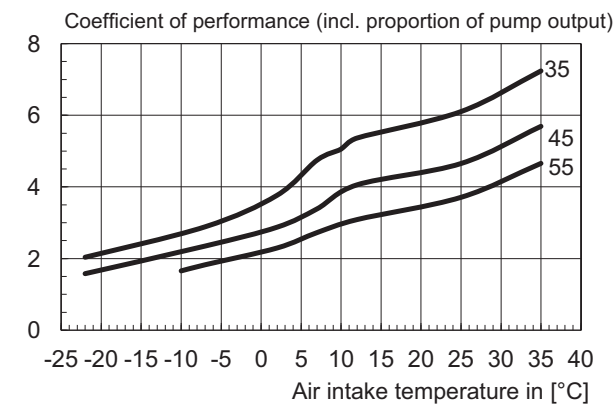
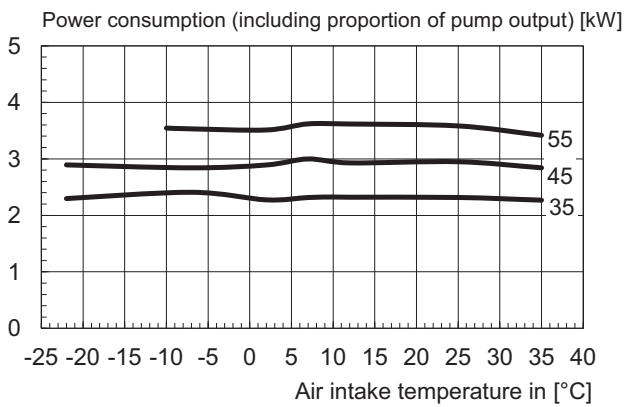
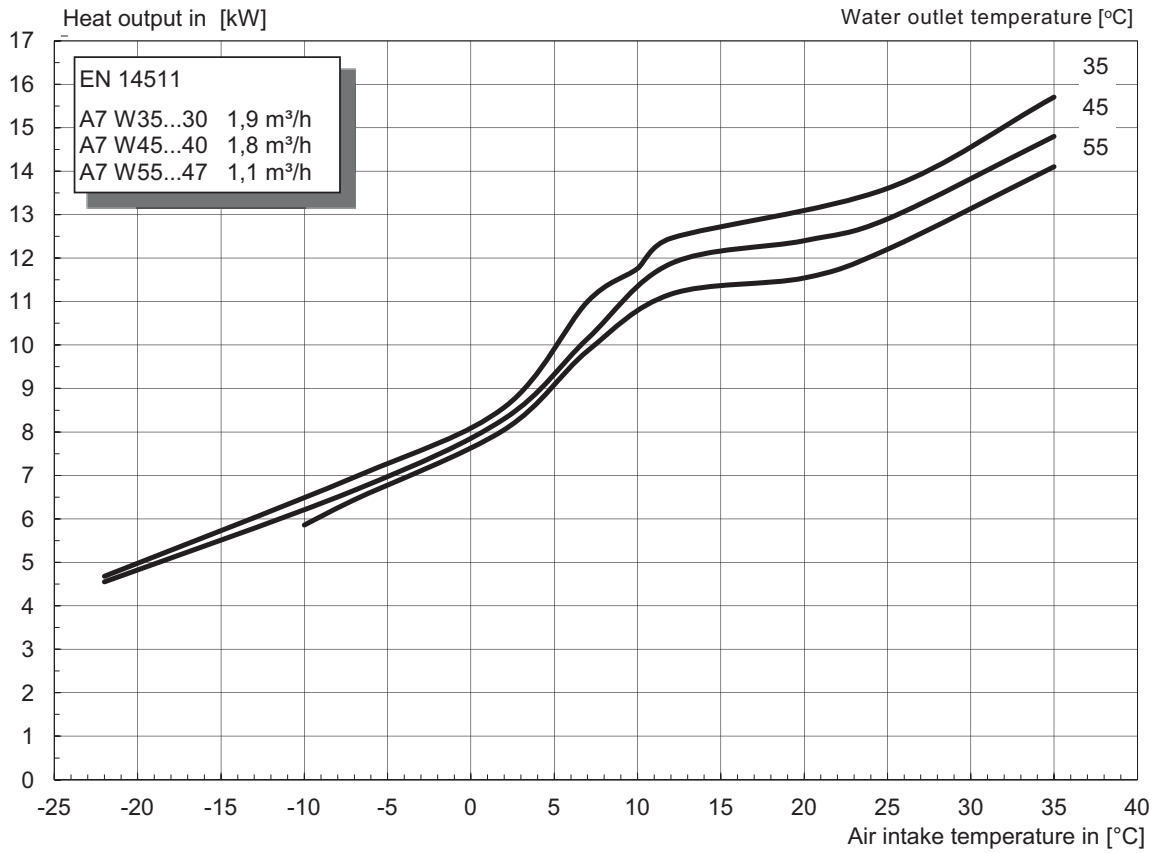

14 Product information as per Regulation (EU) No 813/2013, Annex II, Table 2

Information requirements for heat pump space heaters and heat pump combination heaters				Glen Dimplex Thermal Solutions		Dimplex	
Model	091HOIAOC6						
Air-to-water heat pump	yes						
Water-to-water heat pump	no						
Brine-to-water heat pump	no						
Low-temperature heat pump	no						
Equipped with a supplementary heater	yes						
Heat pump combination heater	no						
Parameters shall be declared for medium-temperature application, except for low-temperature heat pumps. For low-temperature heat pumps, parameters shall be declared for low-temperature application.							
Parameters shall be declared for average climate conditions:							
Item	Symbol	Value	Unit	Item	Symbol	Value	Unit
Rated heat output (*)	Prated	4	kW	Seasonal space heating energy efficiency	η_s	115	%
Declared capacity for heating four part load at indoor temperature 20°C and outdoor temperature T_j				Declared coefficient of performance or primary energy ratio for part load at indoor temperature 20 °C and outdoor temperature T_j			
$T_j = -7^\circ\text{C}$	P_{dh}	4,6	kW	$T_j = -7^\circ\text{C}$	COP_d	2,05	-
$T_j = +2^\circ\text{C}$	P_{dh}	6,1	kW	$T_j = +2^\circ\text{C}$	COP_d	2,94	-
$T_j = +7^\circ\text{C}$	P_{dh}	7,8	kW	$T_j = +7^\circ\text{C}$	COP_d	3,95	-
$T_j = +12^\circ\text{C}$	P_{dh}	8,9	kW	$T_j = +12^\circ\text{C}$	COP_d	4,95	-
$T_j = \text{bivalent temperature}$	P_{dh}	4,0	kW	$T_j = \text{bivalent temperature}$	COP_d	1,79	-
$T_j = \text{operation limit temperature}$	P_{dh}	4,0	kW	$T_j = \text{operation limit temperature}$	COP_d	1,79	-
For air-to-water heat pumps				For air-to-water heat pumps:			
$T_j = -15^\circ\text{C}$ (if TOL < -20°C)	P_{dh}	-	kW	$T_j = -15^\circ\text{C}$ (if TOL < -20°C)	COP_d	-	-
Bivalent temperature	T_{biv}	-10	$^\circ\text{C}$	For air-to-water heat pumps: Operation limit temperature	TOL	-10	$^\circ\text{C}$
Cycling interval capacity for heating	P_{cyc}	-	kW	Cycling interval efficiency	COP_{cyc}	-	-
Degradation co-efficient (**)	C_{dh}	0,90	-	Heating water operating limit temperature	WTOL	60	$^\circ\text{C}$
Power consumption in modes other than active mode				Supplementary heater			
Off mode	P_{OFF}	0,015	kW	Rated heat output (*)	P_{sup}	0	kW
Thermostat-off mode	P_{TO}	0,020	kW	Type of energy input	electrical		
Standby mode	P_{SB}	0,015	kW				
Crankcase heater mode	P_{CK}	0,000	kW				
Other items							
Capacity control	fixed			For air-to-water heat pumps: Rated air flow rate, outdoors	-	3300	m^3/h
Sound power level, indoors/ outdoors	L_{WA}	45/54	dB	For water-/brine-to-water heat pumps: Rated brine or water flow rate, outdoor heat exchanger	-	--	m^3/h
Emissions of nitrogen oxides	NO_x	-	mg/kWh				
For heat pump combination heater:							
Declared load profile	-			Water heating energy efficiency	η_{wh}	-	%
Daily electricity consumption	Q_{elec}	-	kWh	Daily fuel consumption	Q_{fuel}	-	kWh
Contact details	Glen Dimplex Deutschland GmbH, Am Goldenen Feld 18, 95326 Kulmbach						
(*) For heat pump space heaters and heat pump combination heaters, the rated output P_{rated} is equal to the design load for heating $P_{designh}$, and the rated heat output of a supplementary capacity for heating $sup(T_j)$.							
(**) If C_{dh} is not determined by measurement then the default degradation is $C_{dh} = 0,9$							
(--) not applicable							

Information requirements for heat pump space heaters and heat pump combination heaters				Glen Dimplex Thermal Solutions		Dimplex	
Model	121HOIAOC6						
Air-to-water heat pump	yes						
Water-to-water heat pump	no						
Brine-to-water heat pump	no						
Low-temperature heat pump	no						
Equipped with a supplementary heater	yes						
Heat pump combination heater	no						
Parameters shall be declared for medium-temperature application, except for low-temperature heat pumps. For low-temperature heat pumps, parameters shall be declared for low-temperature application.							
Parameters shall be declared for average climate conditions:							
Item	Symbol	Value	Unit	Item	Symbol	Value	Unit
Rated heat output (*)	P_{rated}	6	kW	Seasonal space heating energy efficiency	η_s	120	%
Declared capacity for heating foer part load at indoor temperature 20°C and outdoor temperature T_j				Declared coefficient of performance or primary energy ratio for part load at indoor temperature 20 °C and outdoor temperature T_j			
$T_j = -7^\circ\text{C}$	P_{dh}	6,6	kW	$T_j = -7^\circ\text{C}$	COP_d	2,15	-
$T_j = +2^\circ\text{C}$	P_{dh}	8,4	kW	$T_j = +2^\circ\text{C}$	COP_d	3,09	-
$T_j = +7^\circ\text{C}$	P_{dh}	10,5	kW	$T_j = +7^\circ\text{C}$	COP_d	4,06	-
$T_j = +12^\circ\text{C}$	P_{dh}	12,0	kW	$T_j = +12^\circ\text{C}$	COP_d	5,03	-
$T_j = \text{bivalent temperature}$	P_{dh}	6,2	kW	$T_j = \text{bivalent temperature}$	COP_d	1,89	-
$T_j = \text{operation limit temperature}$	P_{dh}	6,2	kW	$T_j = \text{operation limit temperature}$	COP_d	1,89	-
For air-to-water heat pumps				For air-to-water heat pumps:			
$T_j = -15^\circ\text{C}$ (if TOL < -20°C)	P_{dh}	-	kW	$T_j = -15^\circ\text{C}$ (if TOL < -20°C)	COP_d	-	-
Bivalent temperature	T_{biv}	-10	°C	For air-to-water heat pumps:			
				Operation limit temperature	TOL	-10	°C
Cycling interval capacity for heating	P_{cyc}	-	kW	Cycling interval efficiency	COP_{cyc}	-	-
Degradation co-efficient (**)	C_{dh}	0,90	-	Heating water operating limit temperature	WTOL	60	°C
Power consumption in modes other than active mode				Supplementary heater			
Off mode	P_{OFF}	0,022	kW	Rated heat output (*)	P_{sup}	0	kW
Thermostat-off mode	P_{TO}	0,022	kW	Type of energy input	eletrical		
Standby mode	P_{SB}	0,022	kW				
Crankcase heater mode	P_{CK}	0,000	kW				
Other items							
Capacity control	fixed			For air-to-water heat pumps: Rated air flow rate, outdoors	-	3800	m ³ /h
Sound power level, indoors/ outdoors	L_{WA}	47/54	dB	For water-/brine-to-water heat pumps: Rated brine or water flow rate, outdoor heat exchanger	-	--	m ³ /h
Emissions of nitrogen oxides	NO_x	-	mg/kWh				
For heat pump combination heater:							
Declared load profile	-			Water heating energy efficiency	η_{wh}	-	%
Daily electricity consumption	Q_{elec}	-	kWh	Daily fuel consumption	Q_{fuel}	-	kWh
Contact details	Glen Dimplex Deutschland GmbH, Am Goldenen Feld 18, 95326 Kulmbach						
(*) For heat pump space heaters and heat pump combination heaters, the rated output P_{rated} is equal to the design load for heating $P_{designh}$, and the rated heat output of a supplementary capacity for heating $sup(T_j)$.							
(**) If C_{dh} is not determined by measurement nthen the default degradation is $C_{dh} = 0,9$							
(--) not applicable							

15 Warranty certificate

Glen Dimplex Thermal Solutions

Warranty certificate - System M
(heating heat pumps, central domestic ventilation units)
Valid for Germany and Austria
(issued 11/2019)

The following conditions, describing the requirements and the scope of our warranty service, do not affect the warranty obligations of the seller arising from the sales contract with the end customer. We offer a warranty for the units subject to the following conditions:

Based on the following conditions, we remedy defects on the unit due to material and/or manufacturing defects free of charge, provided they are reported to us without delay upon being detected and within 24 months after delivery to the first end customer. This period is 12 months for spare parts and for commercial use.

This unit is only covered by this warranty if it was purchased by a customer in one of the member states of the European Union, it is being operated in Germany or Austria when the defect occurs, and warranty services can also be rendered in Germany or Austria.

Defects we have recognised as being covered by the warranty are remedied by free repair of the defective parts at our discretion or replacement with fault-free parts. We do not cover exceptional costs of remedying defects due to the type or location of the unit's use or poor accessibility of the unit. The customer must ensure free access to the unit. Dismantled parts which we take back become our property. The warranty period for rework and spare parts ends with the expiration of the original warranty period for the unit. The warranty does not cover easily breakable parts which have only an insignificant effect on the value or usability of the unit. The original purchase receipt, with purchase or delivery date, must always be presented.

The warranty becomes void if the customer or a third party has failed to comply with the applicable VDE regulations, the regulations issued by local utility companies or our installation and operating instructions, or the information on maintenance work and the installation diagrams included in the project planning documents, or if the accessories required for proper functioning have not been used. We accept no liability for the consequences of modifications and work activities performed improperly by the end customer or a third party. The warranty covers the unit and the parts purchased from the supplier. Parts and units not purchased from the supplier, and unit/system defects due to parts not purchased from the supplier are not covered by the warranty.

If it was not possible to remedy the defect, the manufacturer shall either deliver a replacement free of charge or issue a reimbursement for the reduced value. In cases in which replacement is provided, we reserve the right to apply a reasonable utilisation charge for the period of usage elapsed to date. Additional or further claims, in particular regarding compensation for damage caused outside of the unit, are excluded.

It is possible to extend the warranty under certain conditions by taking out a Care Basic warranty package (extension from 2 to 5 years).

For further details, visit:

<https://gdts.one/building-climate-solutions/waermepumpen/system-m/service>

The prerequisite for accepting the extended warranty is chargeable commissioning by the authorised after-sales service for complete systems (see fixed charges in the service price list) with an operational suitability assessment within an operating time (compressor runtime) of less than 150 hours. The chargeable assessment of operational suitability by the after sales service for complete systems is ordered in writing using the corresponding order form or using the online order facility on the Internet (www.dimplex.de/garantieverlaengerung). Complete payment of the fixed charge is a prerequisite for confirmation of the warranty time extension. If any defects are noted in the operational suitability assessment log, they must be remedied. The warranty time extension is confirmed from the address specified below after successful assessment of operational suitability and submission of the log by the after sales service for complete systems to GDTS. The prerequisite is a review of the data in the operational suitability assessment log and approval by GDTS. The warranty ends at the latest 72 months from delivery from the factor or 78 months from the date of manufacture.

The fixed charge includes the work performed to assess operational suitability plus travel costs. No liability is assumed for proper planning, dimensioning and execution of the overall system. Remedying system defects and waiting times are extra services.

The current fixed rates and the associated services can be found on the Internet at: <http://www.dimplex.de/garantieverlaengerung>. There is also an online order form here.

Glen Dimplex Thermal Solutions

Glen Dimplex Deutschland GmbH
Department: Service
Am Goldenen Feld 18
95326 Kulmbach

Tel: +49 (0)9221 709 545
Fax no.: +49 (0)9221 709 924545
E-mail address: service@gdts.one

Internet: www.gdts.one
www.dimplex.de/garantieverlaengerung
www.dimplex.de/seviceauftrag

For order processing, the **type**, the **serial number S/N**, the date of manufacture **FD** and, if specified, the customer service index **KI** for the unit are required.

This information is listed on the unit's type plate.

After-sales service address:

16 Information on the use of data

It is very important to Glen Dimplex Thermal Solutions (GDTS) that your data is handled correctly. We should therefore like to provide you with information on the data collected when operating System M and what happens to this data. The contact details of the data officer at Glen Dimplex Deutschland GmbH (GDD) are set out below, in case you have any further questions.

I. Data collected.

In connection with the commissioning of System M, we need your address and contact details in order to activate the heat pump system and maintain it in future. If you would like to control System M via your tablet or smartphone, you need an app with personal access data. This app is then linked to System M by means of an ID number. Control and operating data on heating performance is also collected in the heat pump itself. This data always relates to the entire property (building) that is supplied by System M, even if several parties live in it. Each System M has a unique ID number that is allocated to the respective contract.

II. Use of the data.

Your contract data (address, contact details) is saved by GDTS in order to implement the contract according to the performance specification. System M's control and operating data is evaluated together with the unique ID, in order to optimize performance and show you and GDTS statistical analyses. Data on the climatic region in which System M is installed may also be included in future for this purpose. The control and operating data is also made available to our after-sales service in the event of malfunctions or errors as well as for regular maintenance, so that this can be performed as effectively as possible. The data is encrypted on all transmission paths using state-of-the-art encryption methods.

III. Use of service providers.

Personal data required for maintenance purposes, such as your address, contact details, and framework data on the contract, is made available to after-sales service partners so that they can carry out maintenance and repair services.

The control and operating data is evaluated and analysed by a service provider; however, this service provider only receives pseudonymised data that does not identify individual persons, but only System M as such. All service providers occupied with this data are bound by non-disclosure agreements under data protection law.

IV. Information on products and new developments.

GDTS will use your contact details on occasion to show you new products and innovations relating to smart homes. If you would not like to receive this information, please cross out this section, or send a message to this effect to the data protection officer at GDD.

V. Right of objection and storage of data.

If you would not like to make available the above-mentioned data in connection with the control and evaluation of System M, you have the option of objecting to the use of this data at any time. To do this, simply send a message to the data protection officer at GDD, whose contact details are set out below.

If the data described is not made available, this could result in restrictions to the agreed services within the framework of a System M service package (see System M service package contract documents).

The contract data together with the contact details will be stored for up to ten years after the end of the contract, as prescribed by law. The System M control and operating data will be anonymised after the end of the contract, so that no link can be made with the contract any more. The data will then be used purely for statistical analysis.

Contact details of data protection officer

Glen Dimplex Deutschland GmbH
Am Goldenen Feld 18
95326 Kulmbach, Germany

Postfach 1280
95303 Kulmbach, Germany

Tel.: + 49 (0) 9221 / 709-100
Fax: + 49 (0) 9221 / 709-924339

Email: datenschutz@gdts.one

17 Declaration of conformity

You can find and download the current CE conformity declaration at:

<https://gdts.one/m>



Glen Dimplex Thermal Solutions

Zentrale

Glen Dimplex Deutschland GmbH
Am Goldenen Feld 18
D-95326 Kulmbach

T +49 9221 709-100
F +49 9221 709-339
dimplex@gdts.one
www.gdts.one

Geschäftsstelle Österreich

Glen Dimplex Austria GmbH
Hauptstraße 71
A-5302 Henndorf am Wallersee

T +43 6214 20330
F +43 6214 203304
info@dimplex.at
www.dimplex.at

Office France

Dimplex SAS
7 rue d'Überach
67590 Schweighouse Sur Moder

T +33 3 88 07 18 00
F +33 3 88 07 18 01
dimplex-ST@dimplex.de
www.dimplex.de/fr