

Typ-Nr. **S14538 S14539**
S14540 S14541
S12542 S14543

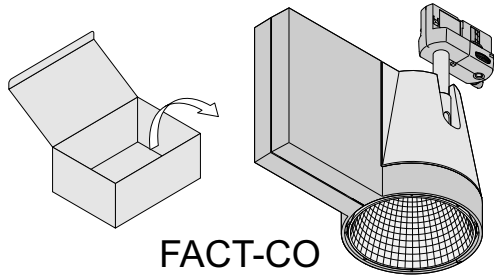

FACT-CO

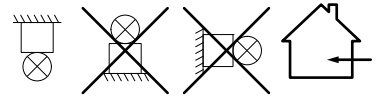
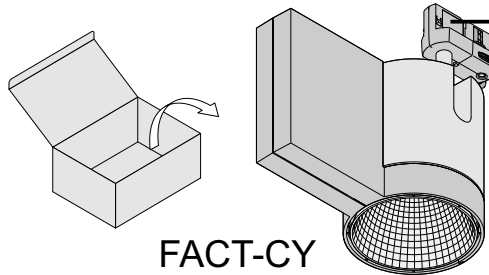

FACT-CY

MULTI-adapter™
GA 69 N ♂ A
6A 250V
 ↓ Fmax. 50N (FI) CE
 (20lbs)
720W 120V 60Hz

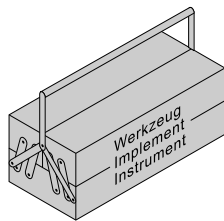
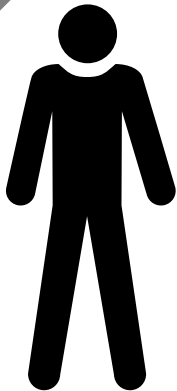
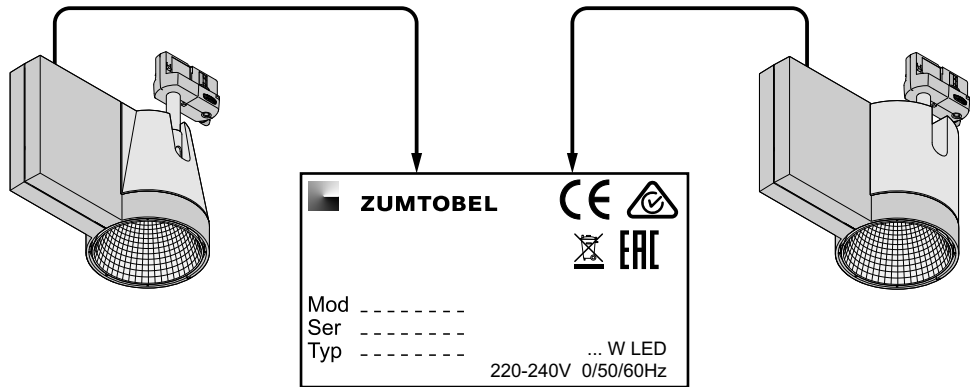

DE Die Montage und Inbetriebnahme darf nur von autorisiertem Fachpersonal durchgeführt werden.

NL De montage en inbedrijfstelling mogen enkel door erkend vakpersoneel worden uitgevoerd.

GB Installation and commissioning may only be carried out by authorized specialists.

NO/SE Monteringen och idrifttagandet får endast företas av auktoriserad fackpersonal.

FR L'installation et la mise en service doivent obligatoirement être effectuées par des techniciens.

FI Asennuksen ja käyttöönoton saa tehdä vain auktorisoitu ammattihenkilöstö.

IT Montaggio ed avviamento devono essere eseguiti solo da personale specializzato.

ES El montaje y la puesta en marcha sólo puede ser realizado por personal especializado autorizado.

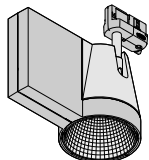

FR Le luminaire sert uniquement à l'éclairage et doit être installé conformément aux prescriptions nationales en matière d'installation. Toute autre utilisation ou installation est considérée comme "non conforme".

NO/SE Armaturen är uteslutande avsedd för belysning och ska installeras i enlighet med de nationella installationsbestämmelserna. All annan användning eller montering gäller som "icke ändamålsenlig".

DE Die Leuchte dient ausschließlich der Beleuchtung und ist entsprechend den nationalen Errichtungsbestimmungen zu installieren. Eine andere Nutzung oder ein anderer Einbau gilt als „nicht bestimmungsgemäß“.

IT L'apparecchio è destinato esclusivamente all'illuminazione e va installato in conformità alle leggi nazionali in vigore. Un altro impiego o un diverso tipo di montaggio non è considerato conforme alle disposizioni.

FI Valaisin on tarkoitettu ainoastaan valaistuskäyttöön, ja se on asennettava kansallisten määräysten mukaan. Muu käyttö tai muu asennus katsotaan sopimuksenvastaiseksi käytöksi.

GB The luminaire is used exclusively for lighting and is to be installed in accordance with the national installation regulations. Any other use or installation is regarded as "not according to instructions".

NL De lamp dient uitsluitend voor de verlichting en dient conform de nationale bouwbepalingen te worden geïnstalleerd. Een ander gebruik of een andere inbouw is niet conform.

ES La lámpara está destinada exclusivamente a la iluminación y debe ser instalada de acuerdo con las pertinentes normas nacionales. Cualquier otro uso o instalación no se considerará "previsto por la norma".

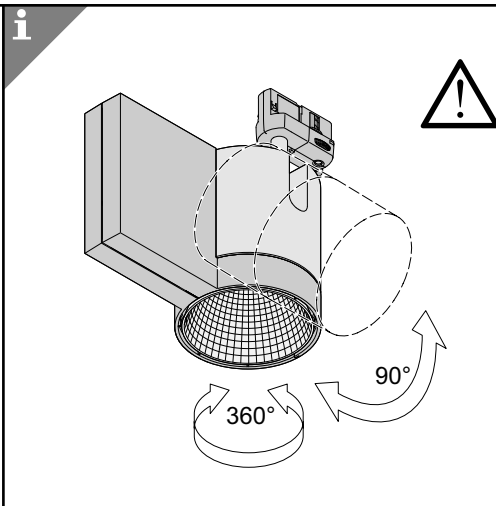
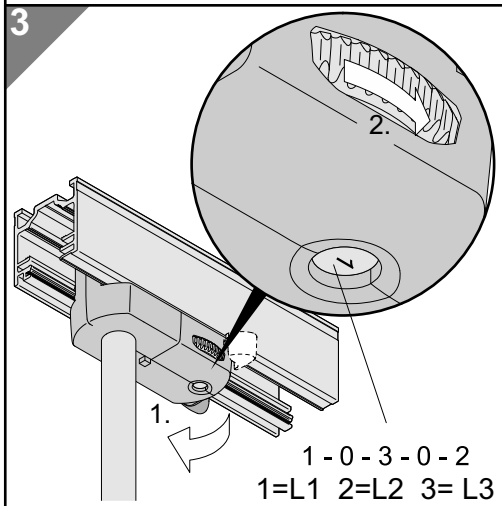
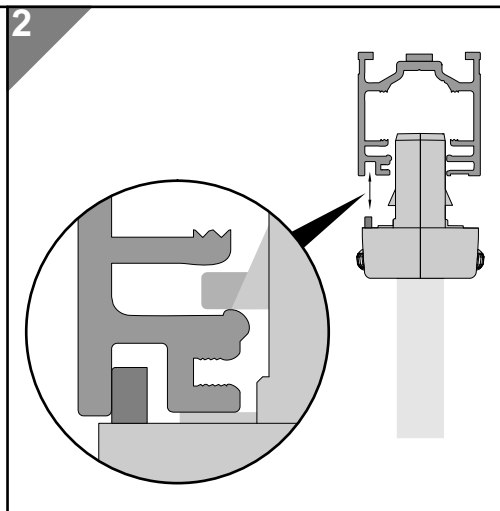
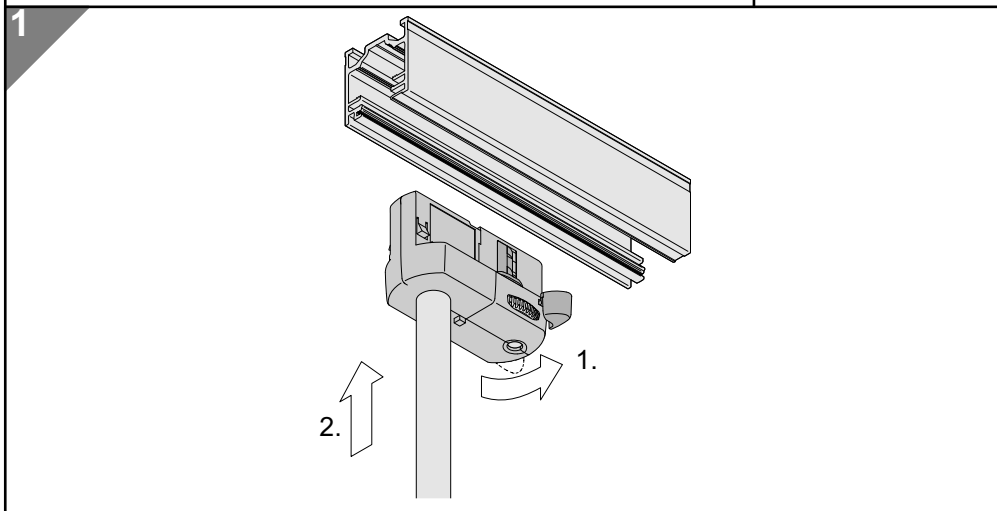
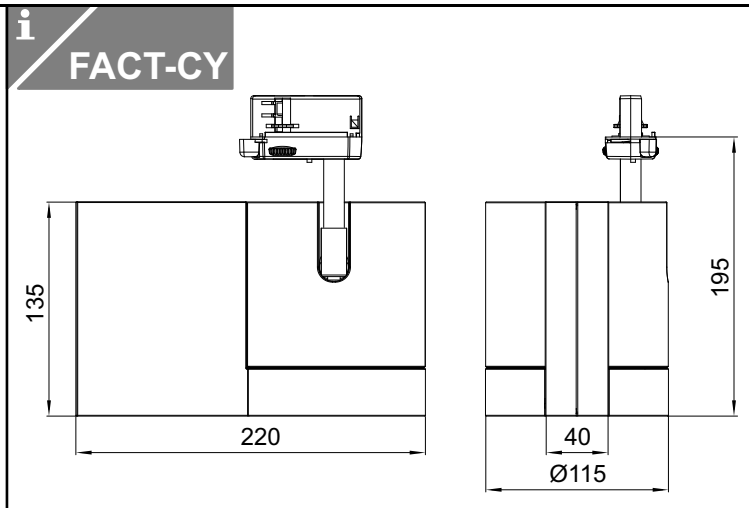
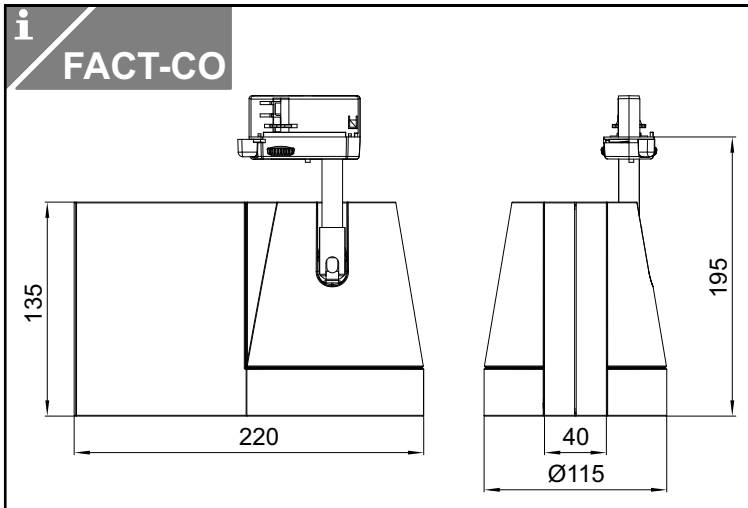

! **DE** Bedienkräfte können zum kurzzeitigen Ausfall der Leuchte führen. Dieses ist kein Reklamationsgrund und beeinträchtigt die Funktion in keiner Weise.
GB Operating forces can lead to short-term failure of the luminaire. This is not a reason for complaint and does not affect the function in any way.
FR Les forces lors de la configuration peut conduire à l'échec à court terme de le luminaire. Ce n'est pas une raison de plainte et affecte la fonction de quelque façon.
NL Bedrijfskrachten kan leiden kortstondige uitval van de lamp. Dit is geen reden voor klacht en invloed op de functie in any way.

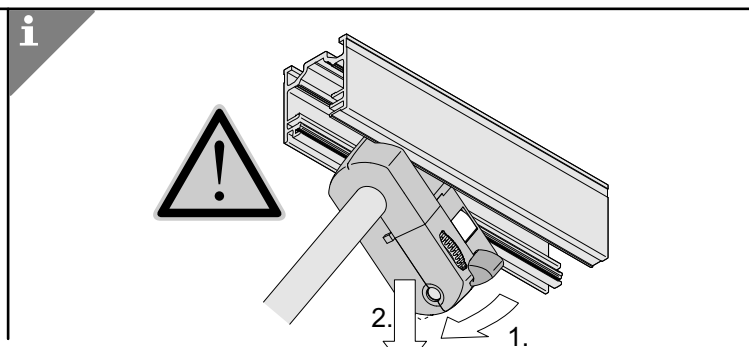
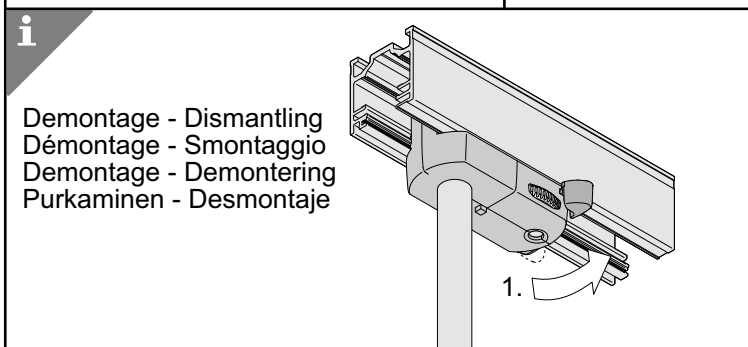

Technische Änderungen vorbehalten. - Specifications subject to change without notice. - Modifications techniques sans préavis.
 Modifiche tecniche senza preavviso. - Technische wijzigingen voorbehouden.
 Med forbehold om tekniske endringer. - Oikeudet teknisiin muutoksiin pidätetään. - Modificaciones técnicas sin preaviso.