

## Montageanleitung

Ⓒ mounting instruction Ⓕ Notice de montage Ⓖ Instrukcja montażu  
Ⓔ Instrucciones de montaje Ⓘ Istruzioni di montaggio

### IPPY...-EDS3

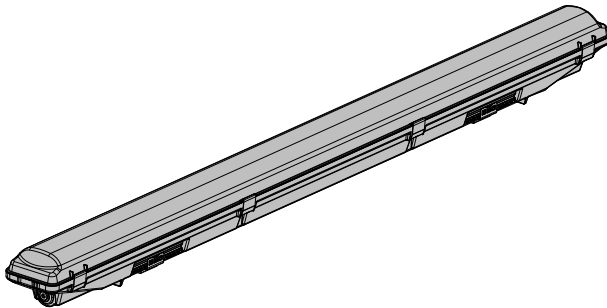

RIDI Leuchten GmbH  
Hauptstrasse 31 - 33 · D-72417Jungingen  
Tel. 07477/872-0 · Fax 07477/872-48  
kontakt@ridi.de · www.ridi.de



- (D) Für die Installation und für den Betrieb der Leuchten sind die nationalen Sicherheitsvorschriften zu beachten.
- (GB) Please note national safety instructions for installation and operation of this luminaire.
- (F) Pour l'installation et le fonctionnement des luminaires il est impératif de respecter les normes nationales de sécurité en vigueur.
- (PL) W celu prawidłowej instalacji i poprawnego działania oprawy należy przestrzegać krajowych przepisów bezpieczeństwa.
- (E) Para la instalación y la puesta en funcionamiento de las luminarias deben observarse las normas nacionales de seguridad.
- (I) Per l'installazione e il funzionamento delle lampade si fa riferimento alle normative di sicurezza nazionali.

- (D) Verwendung der Leuchte in einer Umgebung, in der eine Ablagerung von leitfähigem Staub auf der Leuchte erwartet werden kann.
- (GB) Use of the luminaire in an environment where a conductive deposition of dust on the luminaire is expected.
- (F) Utilisation du luminaire dans un environnement où un dépôt de poussière conductrice peut être attendu.
- (PL) Zastosowanie oprawy w otoczeniu, w którym można się spodziewać osiadania na oprawie pyłu przewodzącego.
- (E) Uso de la luminaria en un entorno en el que pueda producirse una acumulación de polvo conductor sobre la misma.
- (I) Applicazione della lampada in un ambiente in cui è prevedibile il deposito di polvere conduttiva sull'apparecchio.

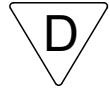

- (D) Die Lichtquelle dieser Leuchte darf nur vom Hersteller oder einem von ihm beauftragten Servicetechniker oder einer vergleichbar qualifizierten Person ersetzt werden.
- (GB) Only the manufacturer, a trained service technician or another equally qualified person is permitted to replace the light source of this luminaire.
- (F) La source lumineuse de ce luminaire ne peut être remplacée que par le fabricant, un technicien de service mandaté par celui-ci ou une personne présentant une qualification analogue.
- (PL) Wymiany źródła światła w tej oprawie oświetleniowej może dokonać wyłącznie producent bądź uprawniony pracownik serwisu albo osoba o podobnych kwalifikacjach.
- (E) La fuente de luz de esta luminaria solamente podrá ser sustituida por el fabricante o una persona designada por este, ya sea un técnico de servicio u otra persona debidamente cualificada.
- (I) La sorgente luminosa di tale lampada può essere sostituita solo dal produttore o da un tecnico di assistenza da questi designato oppure da personale dotato di qualifica equivalente.

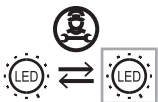

# IPPY...-EDS3

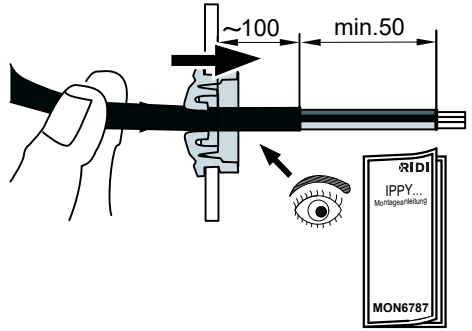
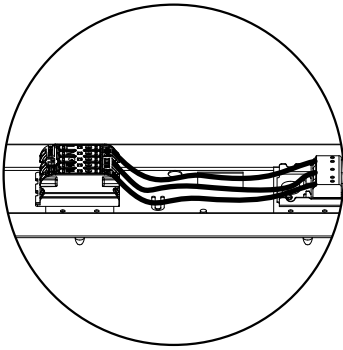
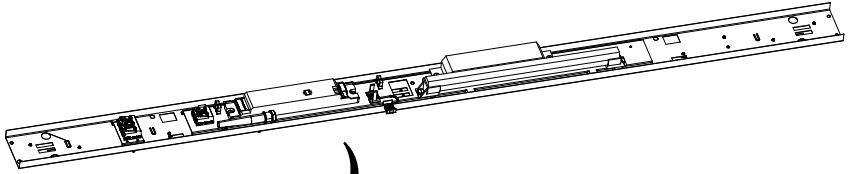
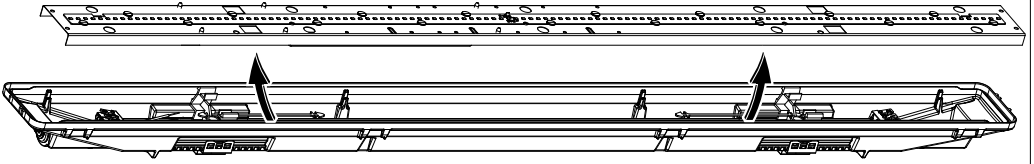

	Ø	A		mm²	A		mm²	A
	0,8-1,2	9	sol.	0,5-1,0	9		0,8-1,2	9
max. ø1,8mm	1,3-1,8	12		1,5-2,5	12	max. ø1,8mm	1,3-1,8	12

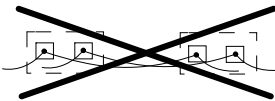
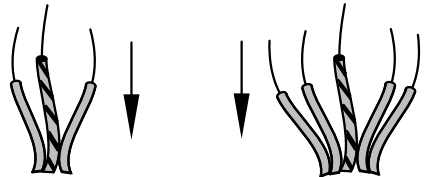
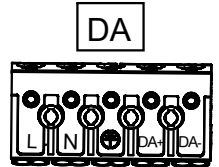
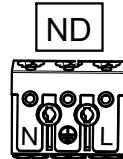

Pos	I (mA)	Flux (lm)	P (W)
0	X	X	X
1	X	X	X
2	X	X	X
3	X	X	X



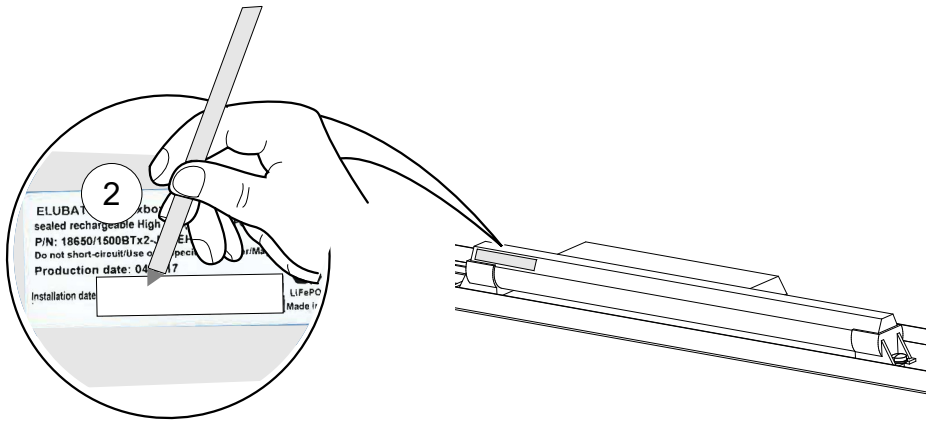
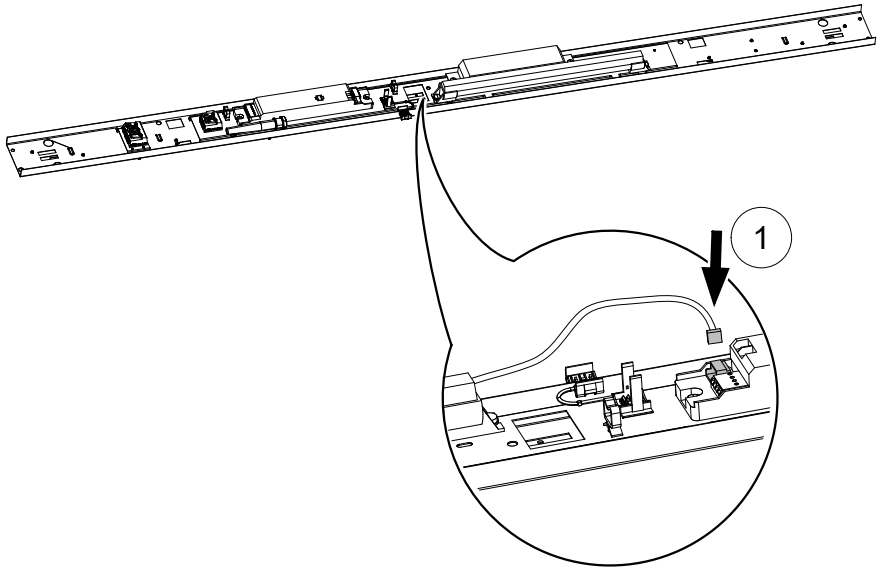

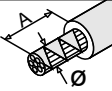
	Ø	A
	0,8-1,2	9
max. ø1,8mm	1,3-1,8	12

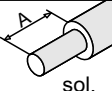
	mm <sup>2</sup>	A
sol.	0,5-1,0	9
	0,5-2,5mm <sup>2</sup>	12

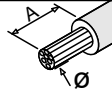
	mm <sup>2</sup>	A
	0,8-1,2	9
max. ø1,8mm	1,3-1,8	12

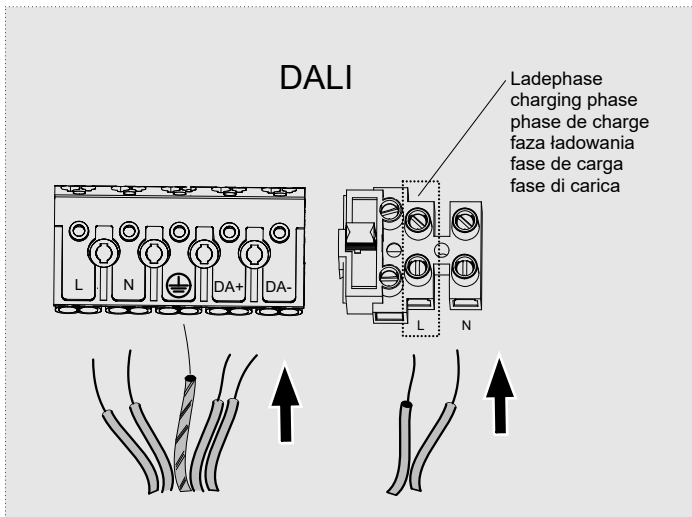
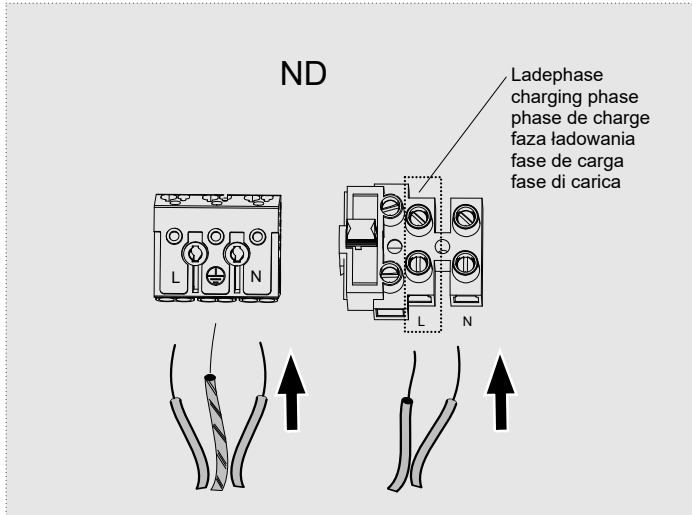



- (D) Austausch nur mit der Original T 2,0A H 250 Sicherung
  - (GB) Warning: Only replace with the original T 2.0A H 250 V fuse
  - (F) Attention, échange seulement avec le fusible original T 2,0A H 250
  - (PL) Uwaga, wymiana tylko na oryginalny bezpiecznik T 2,0 A H 250
  - (E) Atención: cambiar solo por el fusible original T 2,0A H 250
  - (I) Attenzione: cambio solo con il fusibile originale T 2,0A H 250
- 

