

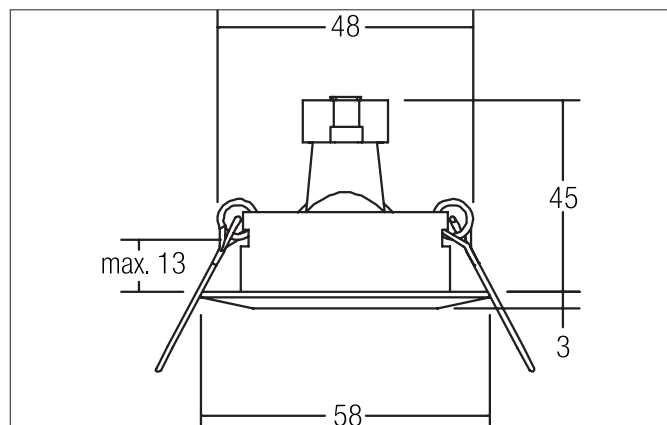

## Recessed downlight, GZ4

Article no. 2103.05



### Tender

Recessed downlight, GZ4, gold, Round. In a compact design, for installation in tool-less rapid assembly systems. Lamp holder: GZ4, Mounting method: Recessed mounting, Place of installation: Ceiling-mounted, Material: Cast iron, Degree of protection: according to DIN EN 60529 IP20, Protection class: (EN 61140) III, Voltage: 12V, Power: 20 W, Amount of light sources / fittings: 1 piece, Light colour: white, Adjustability: Not adjustable, without control gear, Type of dimming: Depending on driver.

Article data	
Article no.	2103.05
GTIN	4250047709138
Short description	Recessed downlight, GZ4
Material	Cast iron
Colour	gold
Type of surface	Glossy
Shape	Round
Outer diameter	60 mm
Built-in diameter min.	48 mm
Built-in diameter max.	48 mm
Installation depth	45 mm
Weight	0.034 kg
D licence plate	No
Conformance	CE, UKCA

**Recessed downlight, GZ4**

Article no. 2103.05

Operating technology of the luminaire	
System output	20 W
Voltage type	AC
AC nominal voltage max	12 V
Frequency max	50 Hz
Lamp	LV halogen lamp
Lamp holder	GZ4
Protection class	III
Degree of protection	IP20
Control	Depending on driver
Bulb change possible	Yes

Mounting technology	
Mounting method	Recessed mounting
Place of installation	Ceiling-mounted
Adjustability	Not adjustable
Further references	No mounting box No cover with thermal insulation material

Packing data	
Gross weight	0.049 kg
Length of packaging	70 mm
Packaging width	37 mm
Packaging height	70 mm
Disposal at end of life	<p>This product must not be disposed of with household waste. You are obliged, to dispose of such electrical waste separately.</p> <p>By disposing of electrical waste and other old or defective electronics separately, you support recycling or other forms of re-use. In that way you help to take care and to avoid that harmful substances get into the environment.</p>