

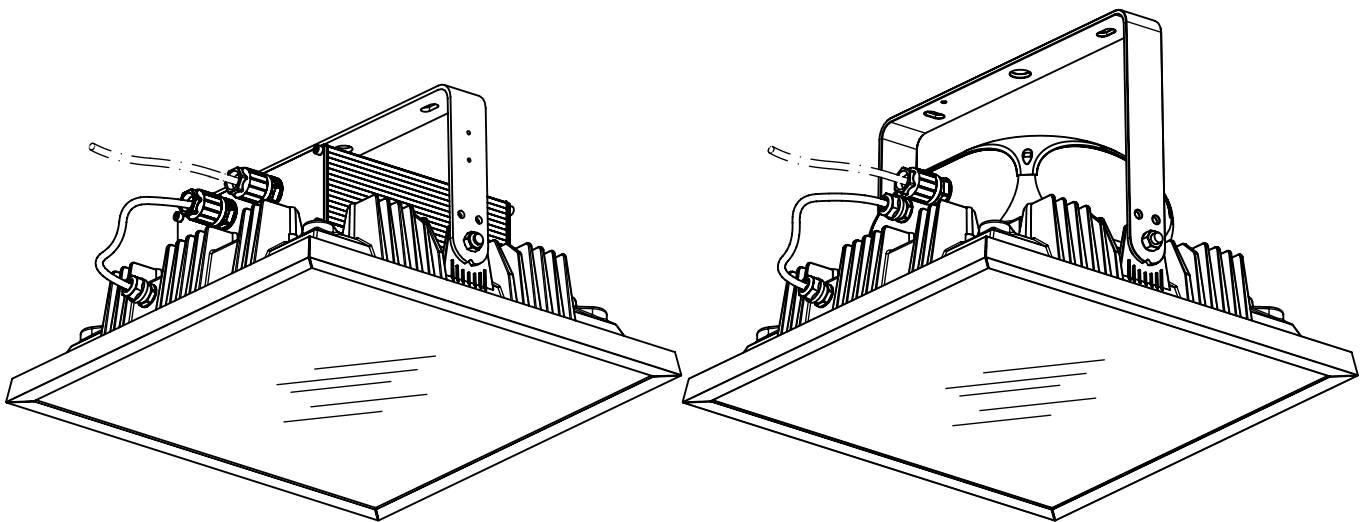

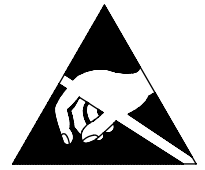





Montageanleitung 80878

- (GB) Mounting Instructions
- (F) Notice de Montage
- (E) Instrucciones de Montaje
- (I) Istruzione per l'Installazione
- (P) Instrucoes de montagem
- (NL) Montage Voorschrift
- (DK) Monteringsvejledning
- (S) Montageanvisning
- (FIN) Asennusohje
- (N) Montasjeveiledning
- (PL) Instrukcja montażu

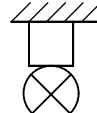
915 ...

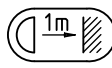

IP 65        

230-240V 0, 50-60 Hz

LED

max. 20,5 kg

$A_p = 0,28 \text{ m}^2$

Diese Leuchte enthält eine Lichtquelle der Energie-Effizienzklasse F
This luminaire contains a light source of energy efficiency class F

NORKA

- (D) Vor dem Öffnen Spannung abschalten.
Die Leuchte darf nur mit ihren vollständigen Schutzabdeckungen betrieben werden.
- (GB) Disconnect power supply before opening.
Luminaire must only be operated with protective cover in place and sealed.
- (F) Couper l'alimentation électrique avant toute intervention sur le luminaire.
Utiliser le luminaire uniquement quand la vasque est fermée.
- (E) Desconectar de la corriente eléctrica antes de abrir.
Sólo manipular la luminaria con el cierre protector colocado y sellado.
- (I) Disconnettere l'alimentazione di rete prima di aprire l'apparecchio.
L'apparecchio deve essere utilizzato solo con il vetro di protezione montato.
- (P) Desconectar da corrente eléctrica antes de abrir.
Apenas manipular a luminaria com o fecho de protecção colocado e selado.
- (NL) Voor het openen, spanning uitschakelen.
Armatuur alleen gebruiken met volledig gesloten afscherming.
- (DK) Afbryd spændingen før armaturet åbnes.
Armaturet på kun sættes i drift når beskyttelsesdækslet er monteret og forsejlet.
- (S) Strömmen måste vara bortkopplad då armaturen öppnas.
Armaturen får endast användas när skyddsglasat är fastmonterat.
- (FIN) Tee jännitteettömäksi ennen avaamista.
Valaisinta saa käyttää vain suojalasi paikallaan ja lukittuna.
- (N) Slå av strømtilførsel før beskyttelse deksel/glass åpnes.
Lysarmatur må kun brukes med beskyttelse deksel/glass på plass og lukket.
- (PL) Przed otwarciem, należy odłączyć zasilanie.
Oprawa może być używana tylko z kompletną pokrywą ochronną.

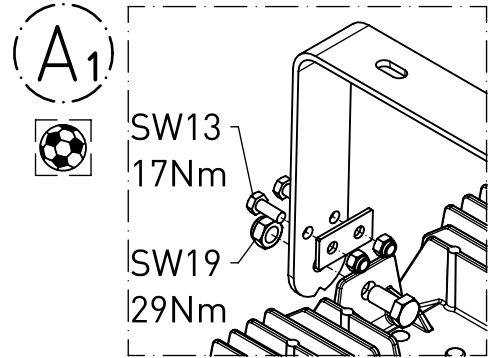
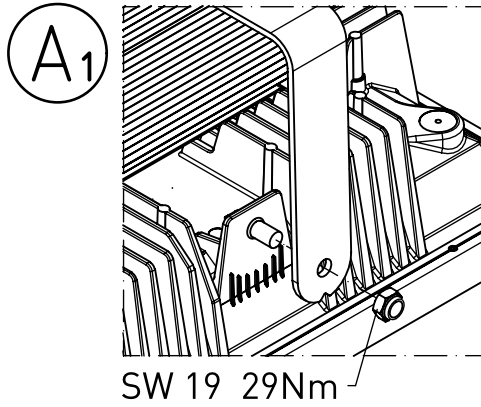

siehe Montageanleitung 78552
see mounting instruction 78552

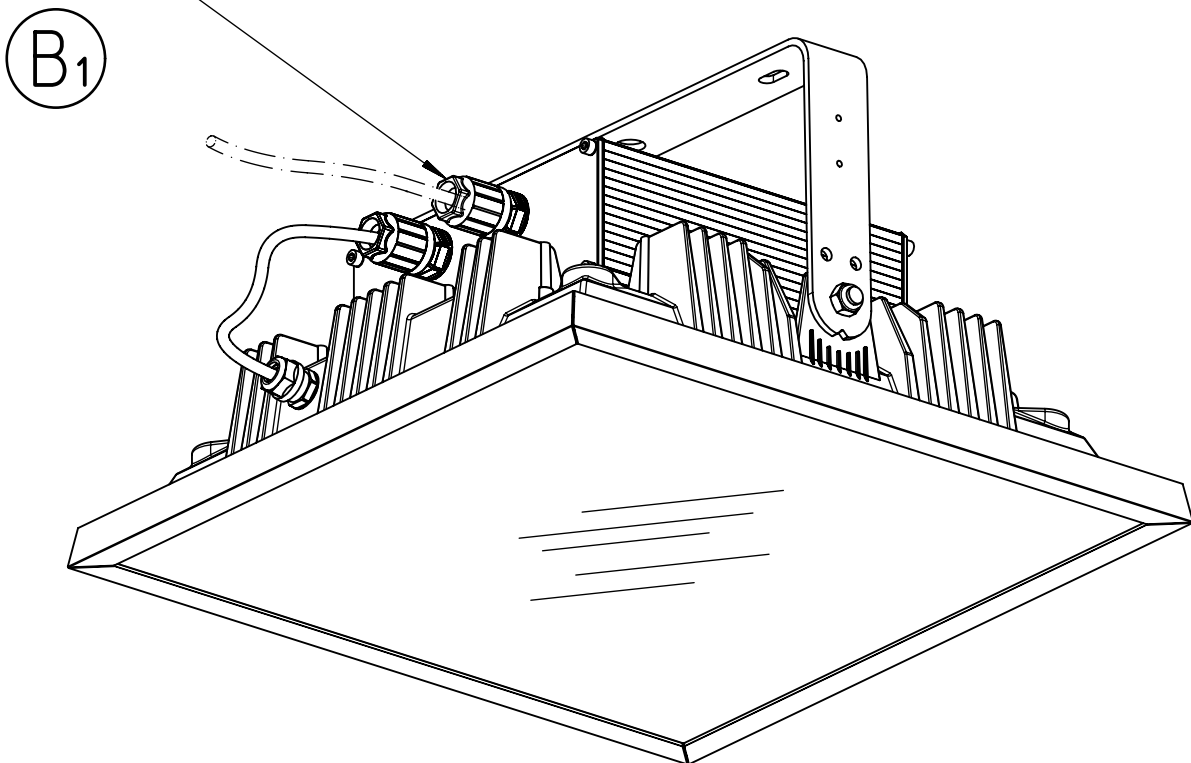

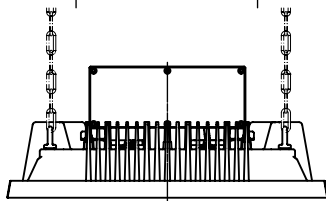
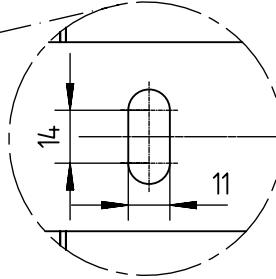
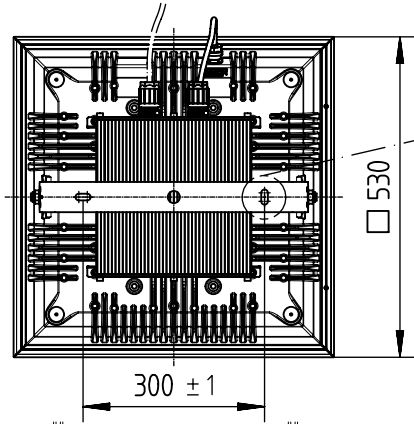
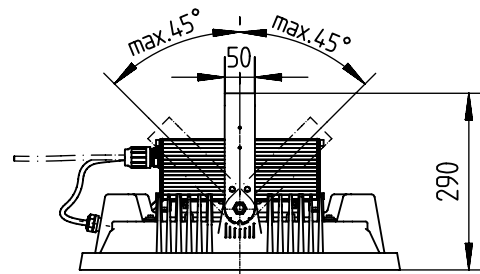
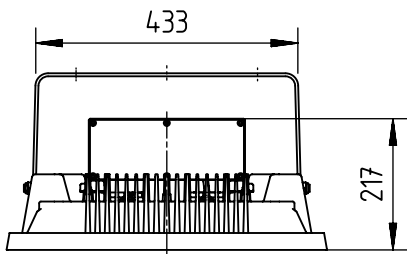

DIN 580
M8

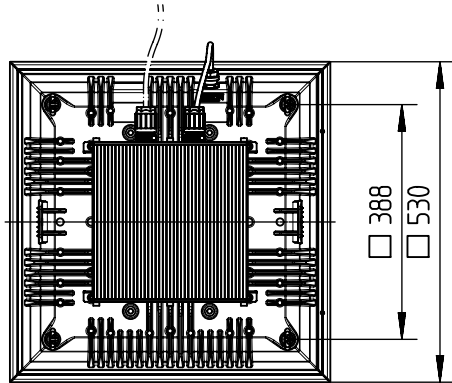
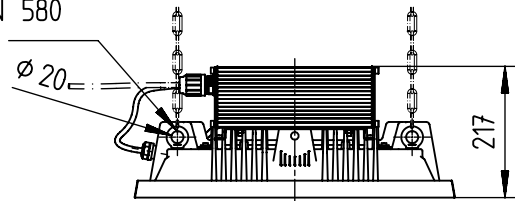

A₂

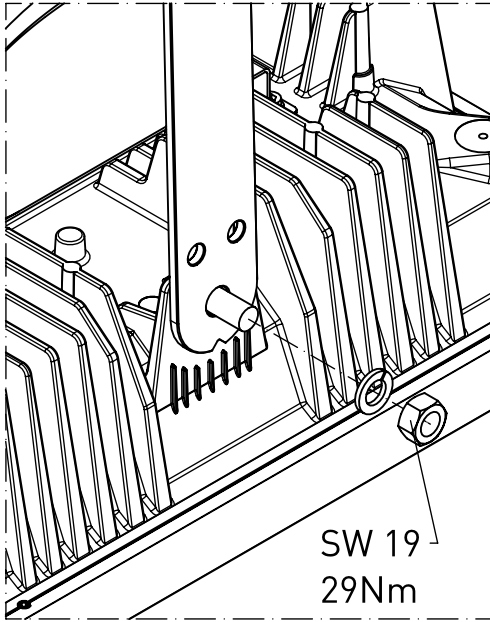

A₂



SW 13
17Nm

SW 19
29Nm

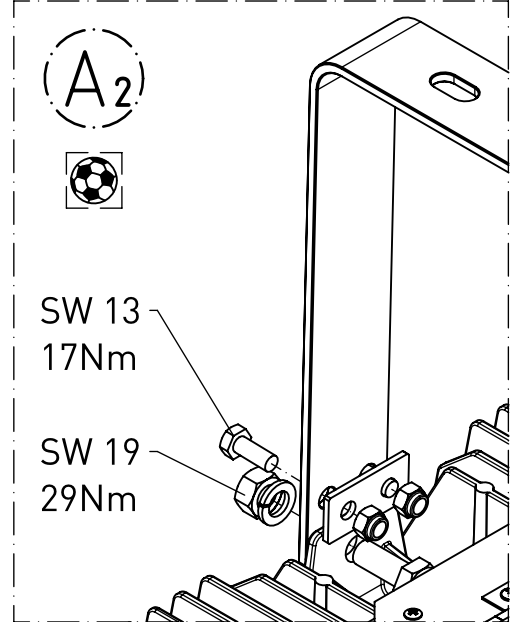

siehe Montageanleitung 78552
see mounting instruction 78552

B₂

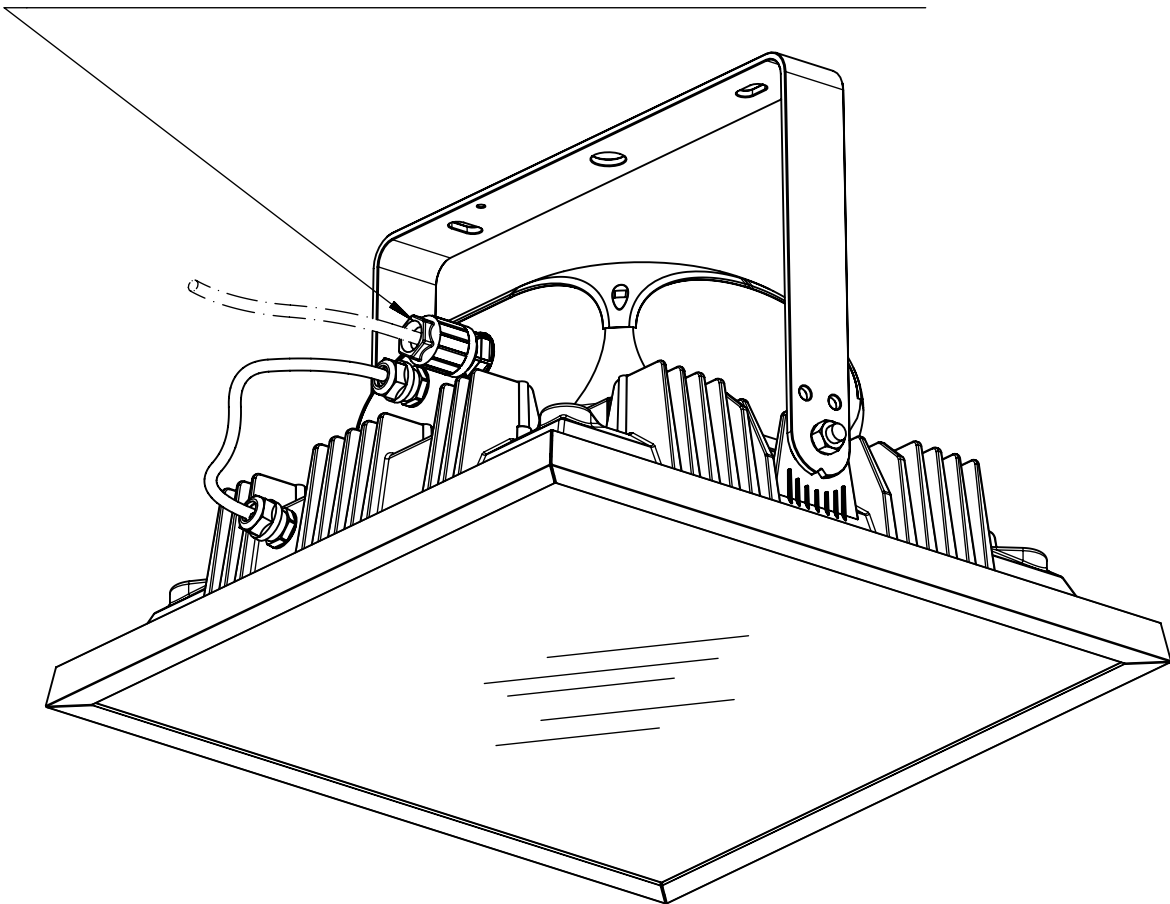

NORKA

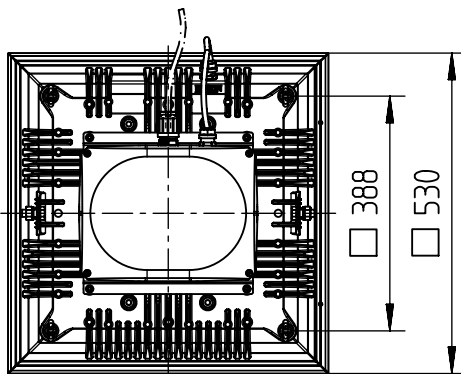
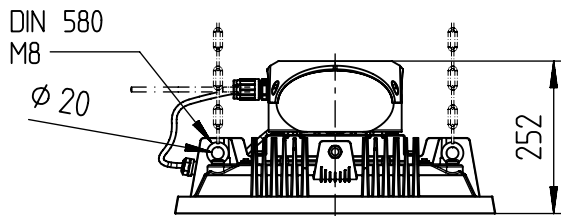
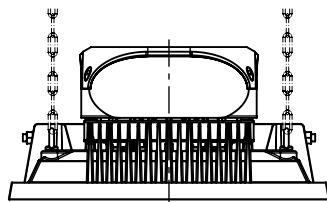
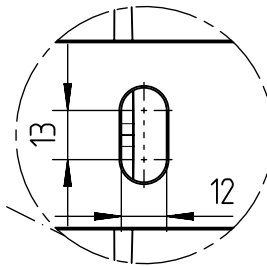
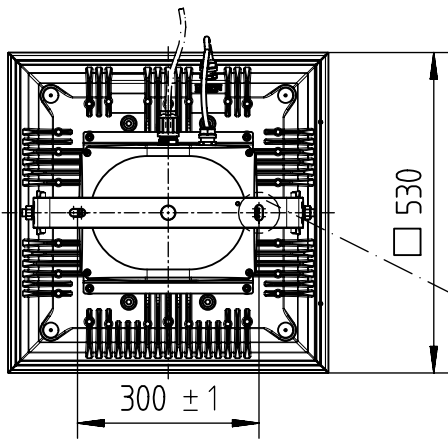
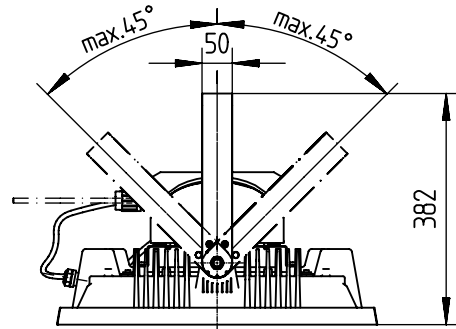
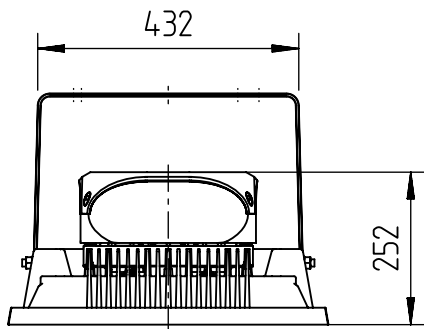

„Zur Vermeidung von Gefährdung darf eine beschädigte äußere flexible Leitung dieser Leuchte ausschließlich vom Hersteller, seinem Servicevertreter oder einer vergleichbaren Fachkraft ausgetauscht werden.“
“if the external flexible cable or cord of this luminaire is damaged, it shall be exclusively replaced by the manufacturer or his service agent or a similar qualified person in order to avoid a hazard.”

„Die enthaltenen Leuchtmittel dürfen nur durch den Hersteller, seinem Servicevertreter oder einer vergleichbaren Fachkraft gewechselt werden.“
„The light source contained in this luminaire shall only be replaced by the manufacturer or his service agent or a similar qualified person.“

 * = „Auch zur Verwendung in einer Umgebung, in der eine Ablagerung von leitfähigem Staub auf der Leuchte zu erwarten ist.“
„Also for use in environments where an accumulation of conductive dust on the luminaire may be expected.“

NORKA

Norddeutsche Kunststoff-
und Elektrogesellschaft
Stäcker mbH & Co. KG

Lichttechnische Spezialfabrik

Kontakt
Weidestraße 122a
D-22083 Hamburg
Germany

Tel.: +49 40 513009-0
Fax: +49 40 513009-28
www.norka.com
info@norka.com